

# Journal of Botanic Gardens Conservation International BGjournal

Volume 23 • Number 1 • April 2026

## LIVING COLLECTIONS AND DATA IN BOTANIC GARDENS



**BOTANIC  
GARDENS**  
CONSERVATION  
INTERNATIONAL

**Editors:**



**Patricia Malcolm**  
Head of Membership &  
Conservation Services



**Carly Cowell**  
Director of  
Conservation Policy  
& Practice

Cover image: Horticulturist updating records using handheld device, Cambridge University Botanic Garden (Howard Rice).

BGjournal and Roots are published by **Botanic Gardens Conservation International (BGCI)**. Each publication is issued twice a year. Articles are contributed by BGCI members. Membership is open to all individuals, institutions, and organisations that support BGCI's aims.

BGCI is a membership organisation representing botanic gardens in more than 100 countries worldwide. We are an independent UK charity, established in 1987, that connects botanic gardens and conservation practitioners through a global network for plant conservation. Our mission is to mobilise botanic gardens and engage partners to secure plant diversity for the well-being of people and the planet. Our global office is based in London, United Kingdom, and we work through separately registered entities, and regional networks to achieve a truly global reach.

**BGCI Global Office**

Botanic Gardens Conservation International (BGCI)  
Charity Reg. No. 1098834  
Company (CLG) Reg. No. 04673175  
199 Kew Rd., Richmond, Surrey, TW9 3BW  
United Kingdom  
+44 20 83325953 [info@bgci.org](mailto:info@bgci.org) [www.bgci.org](http://www.bgci.org)

**BGCI Africa**

Botanic Gardens Conservation International Africa  
Limited  
Company (CLG) Reg. No. CLG-VXFAEQ  
C/O IUCN ESARO  
Mukoma Rd., off Magadi Rd.,  
P.O. Box 68200 - 00200, Nairobi, Kenya  
+254 725295632 [africa@bgci.org](mailto:africa@bgci.org)

**BGCI US**

Botanic Gardens Conservation International U.S., Inc.  
Non-profit organisation 501 (c)(3)  
C/O The Huntington Botanical Garden  
1151 Oxford Rd., San Marino, CA 91108  
United States of America  
+1 303 5798482

**BGCI Regional Networks**

- [African Botanic Gardens Network \(ABGN\)](#)
- [Central America and Caribbean Botanic Gardens \(CCABG\) Network](#)
- [European Botanic Gardens Consortium \(EBGC\)](#)
- [Red Sudamericana de Jardines Botánicos \(RSAJB\)](#)
- [Southeast Asia Botanic Gardens \(SEABG\) Network](#)

Design: John Morgan, Seascape  
[john@seasapedesign.co.uk](mailto:john@seasapedesign.co.uk)

**EDITORIAL**

**03**

Living collections and data  
in botanic gardens

**FEATURES**

**05**

NEWS FROM BGCI  
Cuttings

**07**

FEATURED ARTICLE  
PlantSearch in 2026: From Global Inventory  
to Strategic Living Collections Conservation  
Infrastructure [Patricia Malcolm](#)

**12**

FEATURED GARDEN  
Living Collections at Cambridge University  
Botanic Garden [Sam Brockington et al.](#)

**16**

FEATURED ARTICLE  
BGsmarrt

**17**

INTERVIEW  
PlantSearch: A Conversation  
with Peter Wyse Jackson

**20**

BOTANICAL DATABASES  
Botanical Software

**ARTICLES**

**22**

U-Plant: Database to Support Living Plant  
Collections in Botanic Gardens  
[Marco D'Antraccoli et al.](#)

**27**

Jardín Botánico de la Ciudad de  
Buenos Aires "Carlos Thays":  
An experience in databases  
[Fernando Cano and Graciela Barreiro](#)

**30**

A Novel Paradigm for Plant Information  
Management at Xishuangbanna Tropical  
Botanical Garden [Zhu Renbin et al.](#)

**34**

Reconnecting Kew's Botanical Collections  
[Arnau Ribera Tort et al.](#)

**38**

Analysis of the Functions of the Shanghai  
Chenshan Botanical Garden Living Plant  
Management System  
[Wang Zhengwei and Zhou Wei](#)

**44**

An updated living collections policy at the  
Geneva Botanic Garden [Nicolas Freyre et al.](#)

**48**

The Andaman Plant Biorepository  
Strengthens Living Collections and  
Data Sharing [Anurag Dhyani et al.](#)

**51**

The Living Plant Information System Powers  
Comprehensive Conservation Actions for  
*Magnolia zenii* [Wei Yukun et al.](#)

**53**

Adapting a Living Collections Management  
System for Global Ex Situ Conservation  
[Rebecca Sucher et al.](#)

**57**

Living collections, data and botanic  
gardens' networks: strengthening  
conservation horticulture through training  
[Patricia Malcolm et al.](#)

## LIVING COLLECTIONS AND DATA IN BOTANIC GARDENS

Back in 2017, I was a co-author of a paper published in *Nature Plants* which, for the first time, attempted to measure the proportion of plant diversity grown in the living collections of the world's botanic gardens. The results of that study indicated that botanic gardens grew 30% of described plant species at that time—over 105,000 species. Our primary source of data was BGCI's PlantSearch database, which we estimated covered only about 40% of botanic garden collections, so the actual proportion of plant diversity grown by our community is probably much higher than that 30% estimate.

Yet behind every living collection lies something just as valuable: knowledge. Knowledge on how to grow, manage and conserve that species. This information is essential to farmers, foresters, conservationists and other users of plant diversity in the landscape. I saw this first-hand in 2020, that information is when I joined a review team that visited all of Ethiopia's national tree seed centres (NTSCs) to ascertain, amongst other things, which native species they were able to supply seeds of. The answer was 35 of Ethiopia's > 600 native tree species, and one of the main reasons given was lack of information on seed germination protocols. Much of that information was already known in botanic gardens—we grow ca. 18,000 species of tree—but unavailable to the NTSCs.

Access has historically been a challenge even within our own community. Back in 2017 it was even difficult to obtain material and data from other gardens. PlantSearch, at that time, operated on a blind request system in which gardens could see whether a taxon was held in the living collections of another garden but not the identity of that garden. All requests for material went into BGCI, who passed them on to gardens holding the taxa and, if you were lucky, you might hear back and if you were luckier still you might receive the material you requested.

This edition of *BGjournal* shows how far we have come—and how far we still need to go. Our interview with BGCI's first Secretary General, Dr. Peter Wyse Jackson (pages 17-19) charts the origins of PlantSearch, and the featured article on new generation PlantSearch (pages 7-11) highlights some of its recent developments, including a material exchange mechanism that enables gardens to see who has what and to request material from them directly. Uploaded living collections taxa are now cross-referenced for their taxonomy, conservation status, rarity in cultivation and other attributes, providing added value and knowledge to their curators. However, PlantSearch is only as strong as the data entered into it by contributing botanic gardens, and here the lack of a unified 'global data ecosystem' for botanic gardens with common standards and interoperability is still some way off but very much in our sights.

Encouragingly, progress is being made. Sam Brockington and his colleagues at Cambridge University Botanic Garden (pages 12-15) have been at the forefront of sketching out a vision for that global data ecosystem, and have tested many of the ideas in their own garden. One key element of living collections management that is often overlooked is their transitory nature. Cambridge University Botanic Garden has taken a committed approach to regularly auditing their collections, and using those status updates to better manage them. In doing so they have recognised that one of the weaknesses of many living collection management systems is that plant senescence and death is not systematically recorded, so valuable material is lost. There have been instances where the only *ex situ* collections of Critically Endangered plant species have been lost through lack of active management. For users of PlantSearch working to recover threatened species, it is vitally important that plant material that appears to be available is indeed so.

Collections themselves must also evolve. Of course, it isn't just the plants that live and die over time; botanic garden priorities can also change and, here, it is essential that living collections policies are updated to reflect those changing priorities. An example of this is provided by the Geneva Botanic Garden on pages 44-47.

Critical to managing collections effectively is accessions level software, and this edition of *BGjournal* features a number of these operating systems on page 20. However, as with most tools, it is what you do with the tool that counts most, and in the 'database' section we present examples of how different gardens have tackled the challenges and opportunities related to living collection curation and documentation (pages 22-43).

Most important of all, are the users of our plant collections. Botanic garden living collections are a means to various ends, including research, education, horticulture and conservation (pages 48-56), and optimising their utility for those purposes is key to botanic garden policy and practice.

Finally, one message stands above all: we are stronger together. We can learn from other gardens, work together in networks of collections to create more genetically diverse and useful meta-collections, and drive plant curation and documentation standards up in the process. Case studies from Germany and the Caribbean and Central America are illustrated in the article on pages 57-60. In doing so, we not only improve our own practice—we increase our collective contribution to global plant conservation.

Happy reading!

**Paul Smith,**  
BGCI Secretary General  
March 2026



# FEATURES

---

NEWS FROM BGCI  
**CUTTINGS**

---

FEATURE ARTICLE  
**PLANTSEARCH IN 2026:  
FROM GLOBAL INVENTORY TO  
STRATEGIC LIVING COLLECTIONS  
CONSERVATION INFRASTRUCTURE**

---

FEATURED GARDEN  
**LIVING COLLECTIONS AT CAMBRIDGE  
UNIVERSITY BOTANIC GARDEN**

---

FEATURE ARTICLE  
**BGSMARTR**

---

INTERVIEW  
**PLANTSEARCH: A CONVERSATION WITH  
PETER WYSE JACKSON**

---

BOTANICAL DATABASES  
**BOTANICAL SOFTWARE**

NEWS FROM BGCI

# CUTTINGS

These Cuttings highlight BGCI's recent milestones, from a five-year retrospective of achievements to newly accredited gardens and the organisation's future direction under its 2026–2030 Strategic Framework.



### BGCI Year in Review 2025

BGCI's 2025 Annual Review highlights a year of major global collaboration, innovation and impact in plant conservation.

Key moments included the largest-ever International Congress on Education in Botanic Gardens, hosted in Korea, alongside major regional network meetings across Europe, Africa and South America.

Significant advances were made in conservation tools and partnerships, including the enhancement of PlantSearch to facilitate plant material exchange and the launch of the Illegal Plant Trade Coalition. BGCI's long-term



collaboration with the Franklinia Foundation has now supported conservation action for more than 750 plant species, while the Global Tree Assessment continues to guide national conservation priorities worldwide.

BGCI also strengthened its support to botanic gardens through funding and capacity building, distributing over £1.6 million in grants and delivering training across multiple regions. Projects increasingly link plant conservation with community engagement, recognising people as key custodians of biodiversity.

As 2025 marks the conclusion of BGCI's 2021–2025 Strategy, the organisation looks ahead to its new Strategic Framework (2026–2030), reaffirming its mission to mobilise botanic gardens and partners to secure plant diversity for the well-being of people and the planet.

### BGCI 5-Year Retrospective (2021–2025)

BGCI's 2021–2025 retrospective highlights a period of significant progress towards its goal of mobilising botanic gardens

to prevent plant extinctions and promote a more sustainable planet. Over five years, the global network expanded to around 1,000 member institutions, while major advances were made in plant conservation, including the comprehensive assessment of the world's 58,000 tree species and support for the recovery of more than 500 plant species.

Key achievements include the establishment of 10 Global Conservation Consortia, the launch of the Global Biodiversity Standard, and a doubling of BGCI's grant funding to botanic gardens. The organisation also strengthened its global presence through a new office in Africa, regional presence in Latin America and increased participation in international congresses and networks.



### The Global Biodiversity Standard





**GCC**

Global Conservation  
Consortia



**Acer**



**Conifers**



**Cycads**



**Dipterocarps**



**Ebenaceae**



**Erica**



**Food Plants**



**Magnolia**



**Nothofagus**



**Oak**



**Rhododendron**



Whitebeams, Rowans  
and Service Trees

Despite the challenges posed by the COVID-19 pandemic and limited funding for biodiversity initiatives, BGCI and its partners have demonstrated resilience and impact. This retrospective underscores both the progress made and the continuing importance of collaboration, knowledge sharing and sustained investment in plant conservation worldwide.

### BGCI Strategic Framework 2026–2030

BGCI's Strategic Framework 2026–2030 sets out an ambitious vision to strengthen our role as the world's leading network for plant conservation. Building on our global leadership, BGCI aims to expand our network and increase the number of plant species and habitats under effective conservation action.

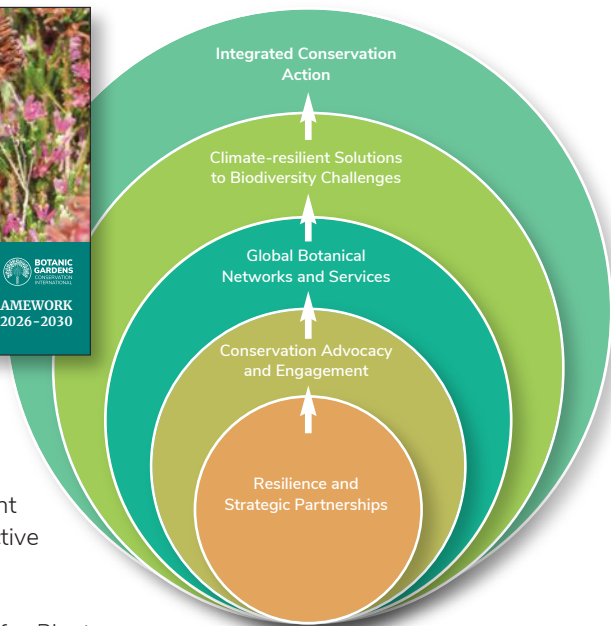
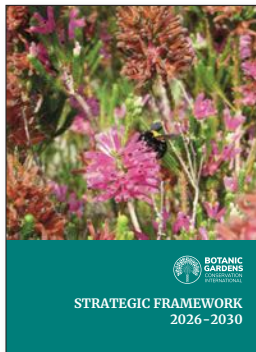

Aligned with the Global Strategy for Plant Conservation and the Kunming–Montreal Global Biodiversity Framework, the strategy defines five key objectives that guide BGCI's work in conservation, knowledge sharing, public engagement and capacity building. These objectives provide a clear foundation for partnerships, programme delivery and measuring impact.

At its core, the framework emphasises the power of botanic gardens and conservation practitioners working together. By mobilising expertise, sharing knowledge and promoting best practice worldwide, BGCI seeks to prevent plant extinctions, restore ecosystems and support sustainable livelihoods.

The mission remains unchanged: to mobilise botanic gardens and engage partners in securing plant diversity for the well-being of people and the planet.



### BGCI Accreditation Scheme

BGCI's Accreditation Scheme continues to recognise botanic gardens that demonstrate excellence in plant conservation, horticulture and public engagement. Accreditation supports gardens in strengthening their impact by encouraging best practice, improving standards and showcasing the value of their work to a global audience.



**BGCI**  
Accreditation  
Scheme

Since the publication of the last BGjournal, a further 9 gardens across diverse regions have been accredited or re-accredited by BGCI.

These include:

- Auckland Botanic Gardens (Australia)
- Botanical Garden, Natural History Museum - University of Oslo (Norway)
- Chelsea Physic Garden (UK)
- Chester Zoo (UK)
- James Cook University - Townsville Campus (Australia)
- Jardín Botánico de Cali (Colombia)
- Jardín Botánico Quilapilun (Chile)
- Natural History Museum of Denmark (Denmark)
- Ness Botanic Gardens, Liverpool (UK)

BGCI congratulates these institutions for their commitment to plant conservation and their contribution to a strong and collaborative global network of botanic gardens.

## FEATURE ARTICLE

# PLANTSEARCH IN 2026: FROM GLOBAL INVENTORY TO STRATEGIC LIVING COLLECTIONS CONSERVATION INFRASTRUCTURE

PlantSearch has long been the world's most comprehensive resource on living plant collections held in botanic gardens and one of BGCI's main assets to the community. Since its launch in 2003, it has evolved from a reporting tool for the Global Strategy for Plant Conservation (GSPC) 2010-2020 Target 8, into a tool for conservation and collections planning rooted in, and supporting, international collaboration. In 2026, PlantSearch sits at a critical transition point. While it is still a simple system at its core, the expectations and demands on it have increased. This article reflects on the current role of PlantSearch, the recent advances which greatly improved its accuracy and the challenges that may be limiting its full potential today. We also outline a vision for its future as a strategic and action-oriented tool supporting botanic gardens.

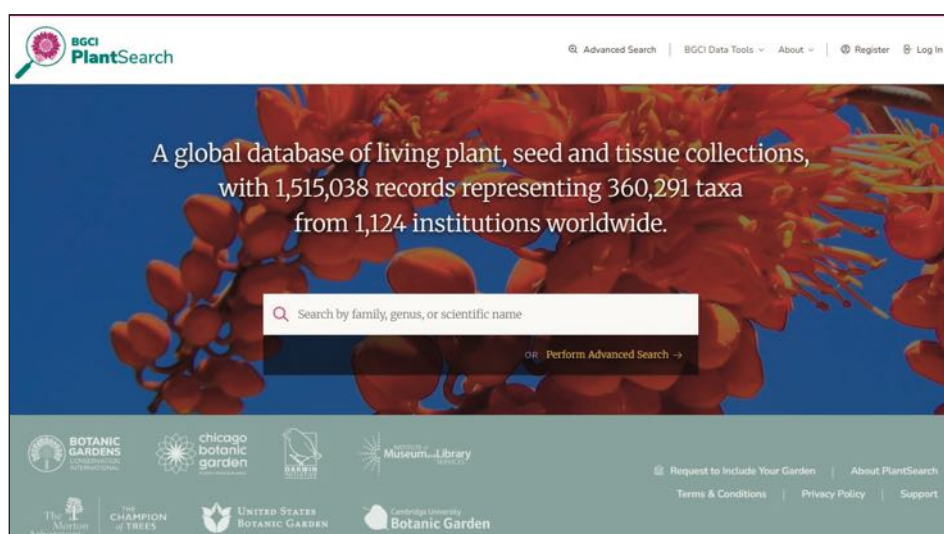

Figure 1: PlantSearch new look since 2023. A simple search and advance searches available, and much easier upload facility for gardens.



[GardensSearch](#) holds information about gardens, their programmes, contacts and infrastructure, and originally it gave many gardens their first online profile, and encourages connections between institutions.

[PlantSearch](#) gathers information about the living germplasm curated by those gardens (this includes whole plants, seeds, cryopreserved and tissue culture, and pollen).

Information for both databases are provided voluntarily by staff in gardens managing those collections, while BGCI funds the maintenance, user support and developments of the databases which are freely available online.

## Its history and why PlantSearch still matters?

Recognising the importance of data-driven decision-making, BGCI has developed and maintains a core set of shared, central repositories, PlantSearch and GardenSearch, which compile essential information on *ex situ* plant collections worldwide. These repositories enable botanic gardens to assess the status of their collections, strategically plan acquisitions and exchanges, and collectively analyse global, regional and national trends in *ex situ* conservation capacity. By facilitating access to comprehensive and up-to-date data, BGCI helps botanic gardens refine their conservation strategies and contribute more effectively to safeguarding plant diversity at a global scale.

When PlantSearch was first introduced, its primary purpose was clear: to provide a global overview of plant diversity held in botanic gardens to measure Target 8 of the 2010-2020 GSPC, thus to track the number of

threatened species held in *ex situ* collections. PlantSearch together with GardenSearch, helped then, and now, position botanic gardens as a collective conservation force rather than isolated institutions.

## Recent developments

Since the last BGJournal article ([Volume 11.2, 2014](#)) focusing in PlantSearch, the tools have changed dramatically. A major turning point came in 2023 with the launch of a redesigned user interface for both platforms (Figure 1). The new interface substantially improved usability, allowing more than one staff member per garden to manage and update data. At the same time, BGCI introduced a much-improved taxon name-checking service. Uploaded names are now matched, including author, against three authoritative references: the World Flora Online (WFO), the World Checklist of Vascular Plants (WCVP), and the International Plant Names Index (IPNI). It also introduced links to ThreatSearch, International Union for Conservation of Nature (IUCN), Convention on International Trade in Endan-

gered Species of Wild Fauna and Flora (CITES), Exceptional Species, GlobalTreeSearch and CropWild Relative information (Figure 2). These changes increased data consistency and reliability across the system, strengthening the value of PlantSearch as a shared resource to analyse the conservation value of collections.

Furthermore, over the past year, PlantSearch has undergone a series of important upgrades, outlined in the next section, that mark a significant shift in how the platform supports the botanic garden community. These changes reflect a recognition that data systems for living collections must serve not only global or academic analyses and/or as reporting tools, but also on the day-to-day realities of garden staff making curatorial decisions.

## Facilitating material and information exchange

One of the most impactful recent developments has been the launch of BGCI's PlantSearch Communication Facility, formerly known as the "blind request" system.

The screenshot displays the BGCI PlantSearch interface. On the left, a sidebar contains various filters: Genus (Nothofagus), Specific Epithet, Intraspecific Epithet, Family, Synonyms (Exclude synonyms), Hybrids (Exclude hybrids), Cultivars (Exclude cultivars), Cultivar Name, and Germplasm Type. The main area shows a list of 34 taxa found, with 'Nothofagus cunninghamii (Hook.) Oerst.' highlighted. The right panel provides detailed information for this taxon, including Family (Nothofagaceae), Name Status (Accepted), external links (WFO: wfo-0000252121, WCVP: 359080-1, IPNI: 128943-3, IPNI: 359080-1), synonyms (Fagus cunninghamii Hook., Lophozonia cunninghamii (Hook.) Heenan & Smissen), Ex Situ Sites (This taxon is found at 38 gardens), Tree status (Yes), ThreatSearch Status (Threatened), IUCN Red List Status (VU), Exceptional Species Status (Insufficient Data), and Crop Wild Relative status.

Figure 2: Filters on the advanced view allows users to pinpoint to specific set of taxa. Each taxon is checked against the external reference name sources with outward links. And also with external sources such as whether if the taxon is a tree (data from BGCI's GlobalTreeSearch), whether it is threatened (according to BGCI's ThreatSearch) and other non-BGCI external sources such as IUCN, CITES, etc.

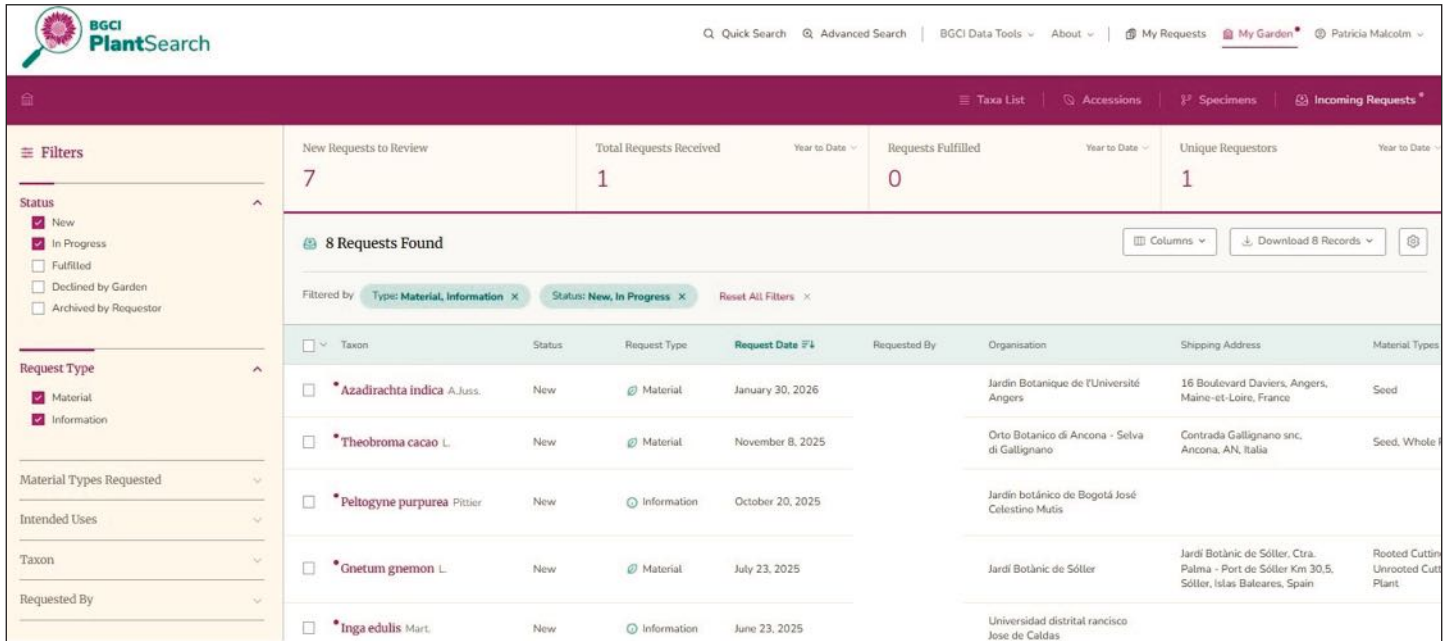

Figure 3: Garden view of the material and information exchange communication facility in PlantSearch. The garden staff can review, download and respond directly to those requesting information or material. And at the same time BGCI can monitor material exchange across the botanic garden community.

This facilitates communication between garden staff at different institutions to request information or material for a particular taxon. It is also accessible to researchers and conservation practitioners outside the botanic garden community.

Garden staff can search for a taxon in PlantSearch, see which gardens holds it, and communicate directly with the relevant institutions to request specific material or information. Because PlantSearch is now fully linked to GardenSearch, all registered staff within a garden can view another institution's documented collections, enabling more precise and informed requests.

Researchers and conservation practitioners (and even the general public) outside the botanic garden community can also submit requests. In these cases, the request remains blind until a garden chooses to respond, ensuring appropriate control and safeguarding of collection data.

For gardens receiving requests, the system can track requests over time, report on how their collection is being used, upload Material Transfer Agreements, and manage communications centrally (Figure 3).

Since its launch in March 2025, the system has processed almost 1,000 requests, with around 40% (for material requests) and 55% (for information requests) receiving a response. For the first time as a community,

we have the insights on collective materials sharing and being able to analyse which taxa are most frequently requested, where demand originates, and how effectively collections are supporting research and conservation outcomes. More in depth analysis as we collect this information is already planned.

### Choosing a principal taxonomic Backbone

At the end of 2025, BGCI implemented one of the most significant advances in PlantSearch's history: the adoption of the World Flora Online as its principal taxonomic backbone. This move, aligned with recommendations under the GSPC, builds on earlier name-matching improvements and introduces a fully transparent revision-tracking system, making PlantSearch more accurate, more reliable, and more valuable for conservationists, horticulturists and researchers worldwide.

Every six months, after WFO releases its updates, PlantSearch automatically refreshes linked taxonomic information and generates a Revision Report for each garden (Figure 4). This ensures that taxon name and status changes resulting from updates in WFO are accurately reflected in PlantSearch. Importantly, searching for an accepted name in PlantSearch now retrieves records held under both accepted names and synonyms according to WFO taxonomy.

This is a major advance for PlantSearch because taxonomic accuracy and the use of up-to-date plant names are fundamental to the effective management of plant collections; almost every decision about a plant depends on knowing exactly what it is. In practical terms, it matters for several reasons:

- Conservation planning and prioritisation and effective collection management. Accurate names allow gardens to identify which species in their collections are threatened, rare, endemic, or legally protected and support better curation decisions. If names are outdated or incorrect, species may be overlooked in conservation planning, duplicated unnecessarily, or excluded from recovery programmes. Accurate names help gardens understand what diversity they hold, what is missing, and where resources should be focused.
- Increases collaboration and data sharing because living collections increasingly operate as part of a global network, a meta-collection.
- Legal and ethical compliance as correct taxonomy underpins compliance with national and international regulations, including CITES, the Nagoya Protocol, and phytosanitary legislation. Misidentified or incorrectly named plants can lead to unintentional legal breaches, especially when exchanging plant material across borders.

The screenshot shows the BGCI PlantSearch interface. At the top, there are navigation links for Quick Search, Advanced Search, BGCI Data Tools, About, My Requests, My Garden, and Patricia Malcolm. Below this is a header with Taxa List, Accessions, Specimens, and Incoming Requests. The main content area is titled '581 Revisions' and includes a 'Download Revisions' button. A table lists taxonomic changes with columns for Taxon Name, Taxonomic Status, Reference, and Accepted Name. Examples include *Abies concolor* (Gordon & Glend.) Lindl. ex Hildebr. being updated to the accepted name, and *Acaena caesiiglauca* (Bitter) Bergmans being updated from synonym to accepted.

Figure 4: On the My Garden Profile garden staff are able to view revisions every 6 months after the match with the new WFO update. The garden is able to download any changes made to the name information on PlantSearch.

- Scientific research integrity as research outcomes are only as robust as the taxonomy behind the plant material.

### Data mobilisation: why sharing data is still hard?

One of the most persistent challenges facing PlantSearch is data mobilisation. Despite widespread recognition of its value, many gardens remain unable to share data consistently and accurately. The current global system that depends on manual, voluntary, episodic uploads may not easily support responsive conservation or curatorial decision-making in this day and age.

Common barriers include:

- Technical and resource limitations, including the lack of automated updates from the garden's own botanic collection software into PlantSearch and resources available in gardens to curate living collections data.
- Skills deficit in conservation horticulture as many gardens have untrained staff or horticulturalists who are not trained to record living collections for conservation or research purposes.
- Lack of standards across the community in terms of data standards but also concepts (i.e. do all gardens sample in the same way? or call an accession the same thing?).
- Concerns about control, intellectual property, and downstream use of data.

- Uncertainty about benefits of uploading data, particularly for smaller or under-resourced institutions.

The concept of the "meta-collection", a globally coordinated network of living collections working together to conserve the full breadth of plant biodiversity, is widely recognised as a best-practice approach for ex situ conservation. However, many botanic gardens still operate independently, with limited collaboration. This is reflected in the data that is held in PlantSearch, which was analysed in depth in Mounce et al. (2017). Without greater investment in data sharing, institutional partnerships, and capacity-building efforts, global ex situ conservation efforts remain incomplete.

### What's next?

While questions such as "Is a species held in cultivation? How many gardens grow it? Is it represented outside its country of origin? How many of those are threatened?" remain important in 2026, there is growing recognition that they are no longer sufficient. At the same time, with the intensification of the biodiversity crisis, gardens are being asked not just to hold plants, but to demonstrate impact, strategy, and accountability. PlantSearch remains central to this effort, but it must now function as more than an inventory.

### PlantSearch in the near future

For conservation and scientific research, collections with accurate taxonomic identification and precise provenance information hold exceptional conservation value. The identification of WFO as the primary taxonomic

backbone for PlantSearch in 2025, gives us the first step to make it easier to share plant information across gardens. While the provenance information in PlantSearch will be launched this year with the accessions level module. This will allow gardens not only to see which taxa another garden has, but also how many accessions of that taxa and which ones are from wild provenance, making material exchange and gap analysis a lot more powerful and meaningful for conservation.

The accession level module will also open the opportunity to add analytical tools such as BGsmartR (see page 16). We hope this powerful tool for collection analysis will be available as a plug-in of PlantSearch and used hand in hand with BGCI's Accreditation Scheme, giving gardens a framework for maturity.

### Towards a new global living collection ecosystem

PlantSearch has already transformed how botanic gardens understand themselves as a global network. In 2026, the challenge is to complete that journey, from knowing what we have to understanding why it matters and how it should be used.

The vision recently articulated in Brockington et al. (2026) calls for a global information ecosystem that empowers botanic gardens to connect, share, and analyse their living collections data, enabling informed, collaborative and collective decisions to manage and safeguard plant diversity.

But this is not only a technical vision but one that should be accompanied with a culture of knowledge-sharing, establishment of global standards for conservation horticulture practice, guided by an advisory group of experts, and supporting gardens through a framework of maturity and capacity building.

By equipping our leaders with information and insights to champion living collections and their management, ex situ conservation will become a strategic institutional priority, embedded at the heart of every botanic garden's mission.

## References

- **Brockington, S., et al. (2026).** High-performance living plant collections require a globally integrated data ecosystem to meet twenty-first-century challenges. *Nature Plants* <https://www.nature.com/articles/s41477-025-02192-6>.
- **BGCI. 2004.** Developing Targets for the International Agenda. *BGjournal* 1.1.
- **BGCI. 2010.** Ex situ conservation: the value of plant collections. *BGjournal* 7.1.
- **BGCI. 2014.** Botanic gardens: Using databases to support plant conservation *BGjournal* 11.2.
- **Cano, Á., et al. (2025).** Insights from a century of data reveal global trends in ex situ living plant collections. *Nature Ecology & Evolution*, 9(2), 214–224. <https://www.nature.com/articles/s41559-024-02633-z>.
- **Mounce, R., et al. (2017)** Ex-situ Conservation of Plant Diversity in the World's Botanic Gardens. *Nature Plants* 3: 795-802 <https://www.nature.com/articles/s41477-017-0019-3>.

## Acknowledgements

PlantSearch is dedicated to the memory of Diane Wyse Jackson, a passionate visionary for botanic garden data sharing. The development of the current version of BGCI's PlantSearch was made possible with the support of the several organisations listed on the web application and BGCI's members, who support our work. Thank you to all

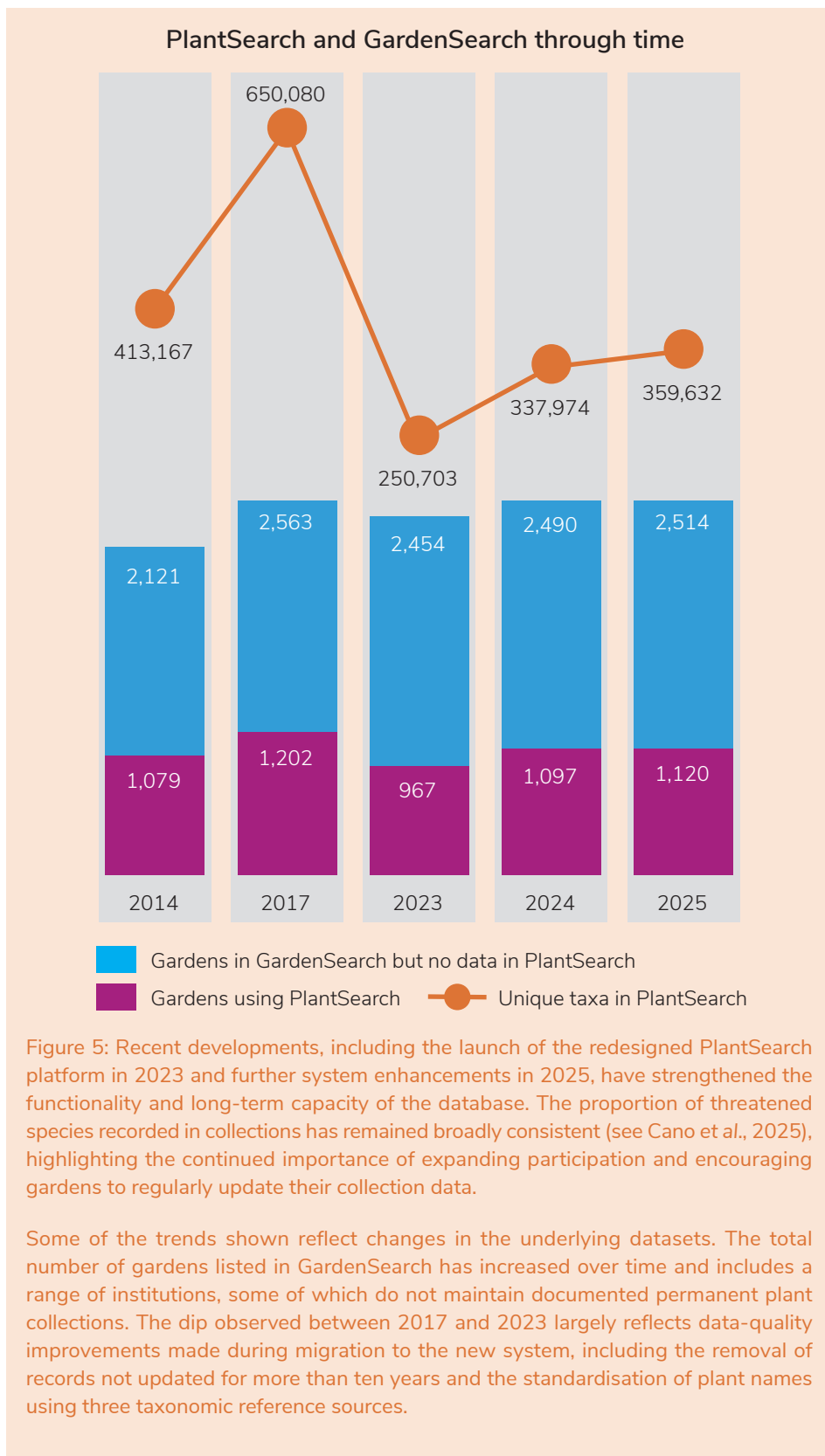

those garden staff who curate and update their records on PlantSearch. I would also like to thank those staff at BGCI who worked over the years on PlantSearch, especially Suzanne Sharrock, Abby Meyer and Meirion Jones; and Keith Damiani who designed the current web application.

**Patricia Malcolm,**  
 Head of Membership &  
 Conservation Services,  
 BGCI.  
[patricia.malcolm@bgci.org](mailto:patricia.malcolm@bgci.org)



Cambridge University Botanic Garden (Howard Rice).

## FEATURE GARDEN

# LIVING COLLECTIONS AT CAMBRIDGE UNIVERSITY BOTANIC GARDEN

## Our Vision

Cambridge University Botanic Garden was founded in 1846 and is one of a broad array of exceptional collections at the University of Cambridge, collectively holding some 15 million objects that support and promote learning and research. Our living collections include over 6000 plant species from around the globe and across the taxonomic spectrum. We aim to steward a diverse, sustainable, well-documented, and high-value collection of plants that serves the botanic garden meta-collection, our partner institutions, our academic communities, conservation initiatives and of course the public. These core ambitions drive our priorities, define our relationships, and shape our processes. Over the past decade, we have also sought to contribute leadership within the global botanic garden community

through a living collections philosophy centred on data-driven excellence. While data will never capture all the intrinsic and extrinsic value of living collections, they are an essential tool for honest commentary. And in this context, we have aimed to use our data and data tools to articulate our achievements and challenges, both as an individual institution and as an international community working towards shared goals.

## Important Lessons

### Learning to embrace transience

Living collections are constantly growing, changing, dying, reproducing, intermingling, and moving. Capturing this change through data requires sustained effort, but it also generates immense value. Regular auditing and status updates are integral to recording

the dynamics of a living collection and play a central role in maintaining data quality. By systematically observing and documenting our collections, we can inform future acquisitions, planting schemes, and research questions. Quite simply, it is the very data that documents transience that transforms living collections into valuable research infrastructure.

### Integrating curation and horticulture

Previously, we operated with separate teams dedicated to curation and horticulture, but more recently we have moved towards a more flexible structure in which horticulturists incorporate curatorial principles into their daily practice. This cultural shift is intended to facilitate horticultural staff to make data-informed decisions about the plants and areas in their care, while the curation team is increasingly embedded within horticultural practice, enabling more efficient problem-solving and the optimisation of routine processes. If horticulture is to contribute to broader conservation goals through meta-collections, and if living collections data are to function as research infrastructure, then horticultural staff must be supported and empowered to act as collections managers and curators.



We have established equitable partnerships in many temperate hotspots, including in the Cape Region of South Africa with Stellenbosch University Botanic Garden (Margeaux Apple).

### Investing in technology

Over the past decade, we have invested heavily in technology to improve our collection management. By investing in a user-friendly database, mobile data devices and bar-coding technologies, we have found that we can democratise record-keeping across horticulture and curation staff, supplementing a system that previously depended on a single individual for digitisation. We have introduced laser engraving for labels that allowed us to rapidly replace all of our 14,000 labels, but also find that labels are an inherent weak point in the information chain. So more recently we have employed, high-precision GPS mapping for routine plant location and to strengthen the link between plants and records: with precise spatial data, plants remain locatable even if labels are lost.

### Training and review

With a democratised data-management system, both all horticulture and curation staff now contribute to record-keeping and curation practices more generally. Ensuring consistency across individuals and over time requires ongoing communication, training, and evaluation. Our first formal articulation of the policies and procedures underpinning curatorial practices is the [Living Collections Manual](#). This comprehensive reference provides the framework within which all members of staff can confidently and

effectively contribute to regular audits, verifications, creating records and other integral aspects of curation.

### Key Steps Towards Our Vision

Over the past decade, we have re-engineered and refined our curatorial processes. Below, we outline several of the steps we have taken, reflecting on the values driving them, how we have shaped these processes, and the challenges associated with their implementation.

#### Publishing our meta-approaches

Major developments in our approach have often been marked by significant publications, which, as a research-intensive university botanic garden, we consider an important output of our work. In 2017, in collaboration with BGCI, we analysed the content of the world's living collections to establish baselines relevant to the Global Strategy for Plant Conservation (GSPC) objectives (Mounce et al., 2017). This work, and its publication, played a key role in shaping and launching our [Living Collections Strategy 2020–2030](#).

Since embarking on this strategy, we have developed a suite of metrics to evaluate collections quality and trajectory over time. Tracking these indicators allows us to assess the impact of our policies, understand long-term trends, and make informed decisions

about sourcing priorities, the identification of high-value accessions, and candidates for de-accessioning. Because these variables are quantifiable, we have invested in informatic tools to support efficient, evidence-based curatorial decision-making.

Our most comprehensive tool to date, BGsmartR (see page 16 for more information on BGsmartR), analyses database extracts to generate interactive visualisations of collections quality and change, enabling us to move from intuition-led to evidence-led management. This tool kit directly led to our subsequent research demonstrating global trends in living collections (Cano et al., 2025), as well as our paper outlining the need for high-performance collections embedded within globally integrated data ecosystems to meet twenty-first-century challenges (Brockington et al., 2026).

#### Publishing our Collections Manual

Our [Living Collections Manual](#), published in 2026, codifies the procedures governing the curation and care of CUBG's living collections. It serves as a comprehensive reference for staff, articulating the decision-making frameworks that guide collections management and reflecting the shared aspirations of horticulture and curation teams to maintain the highest standards of documentation. Given the close integration of horticultural practice and curatorial oversight, clear communication of policies and procedures is essential to preserving records integrity.

The manual also provided an opportunity to review, consolidate, and refine best practice. We sought to balance operational guidance with aspirational goals and to create space for continual scrutiny and improvement. Draft chapters were discussed and debated in a series of cross-team meetings. The resulting document represents the culmination of decades of collective experience, years of planning, months of discussion, and days of editing.

With its publication, we present our current approach to collections management. It is not final. As CUBG evolves, so will this document. But we hope it will serve as both a baseline for internal continuity and a resource for the wider botanic garden community, supporting comparison of curatorial practice and sparking meaningful conversations that advances our shared mission.



Integration between curation and horticulture looks like working together to audit the collection (Howard Rice).

### Building and maintaining partnerships

To ensure a steady influx of new material, we organise and participate in collecting expeditions and cultivate equitable partnerships overseas. These activities strengthen the authenticity of our collections through wild-sourced material and through identification by local botanical experts. Our Living Collections Strategy identifies regions aligned with current and projected climatic suitability. We have since developed partnerships in Chile, Croatia, Kyrgyzstan, and South Africa and are conducting seed-collecting expeditions with our partners.

Building and sustaining such relationships is complex, given differing institutional cultures, requirements, and goals. Clear communication and equitable exchange are important and time-intensive. We have employed an Expedition Botanist, which despite the adventure of the title, is mostly about building and maintaining relationships. Many of these relationships are personal friendships as well as professional, and we have sadly lost dear collaborators in the past couple of years. As staff loss and turnover can disrupt these personal connections, we prioritise institutional-level Memoranda of Understanding that articulate shared objectives and ethical frameworks.

### Institutionalising audits and status updates

Capturing the dynamic nature of living collections provides a vital snapshot of their composition and condition and informs both immediate and long-term decision-making.

Auditing enables a holistic understanding of the collections, including survival and mortality patterns, phenology, growth rates, and overall condition. It also supports taxonomic verification and the maintenance and improvement of labelling.

The value, and challenge of audit data lies in accuracy and consistency. The introduction of mobile technologies and broader staff participation has increased both the volume of records and the potential for inconsistency. To mitigate this, all horticultural staff participate in one-to-one auditing sessions with the curation team. These sessions reinforce standards, clarify which fields require updating, and provide a forum for discussion of curatorial issues.

Our Living Collections Strategy requires that all records be updated within a four-year cycle. This rolling target encourages close, regular engagement with the collections, often revealing data errors, prompting urgent propagation, or highlighting verification needs. It also allows space to rediscover and appreciate the diversity of the collection. Engaging all staff in auditing fosters shared responsibility, which we aim to strengthen through continued training and professional development.

### Developing frameworks of value to enable deaccessioning

Not all plants serve the same purpose, and their value varies accordingly. Some are primarily aesthetic; others support research, or education. Some have high curatorial value due to rarity in cultivation, threatened status, or wild provenance. At the other end

of the spectrum are plants retained largely through inertia, consuming resources that could support more significant accessions. Even high-value plants may ultimately require removal if they are not suited to our landscape or pose safety risks.

We have therefore developed parallel systems to identify and safeguard our most valuable plants, and to assess and responsibly de-accession material that no longer aligns with our objectives. These initiatives aim to enhance collections quality and long-term sustainability. Led by the curation team in consultation with horticulture and learning staff, this work has involved defining key criteria, designing labelling and database systems, and developing informatic tools to support decision-making.

The valuation project involves auditing high-value plants, introducing new labels indicating value and protection requirements, and implementing targeted management actions. The pilot will run for approximately one year, after which staff feedback will inform further refinement. Our de-accessioning project includes the development of ditchR, an informatic tool that consolidates relevant information that should be evaluated before making a final decision. We are now using that program to assess whether it is appropriate to deaccession individual plants, and at collection-wide scale to identify potential de-accessioning candidates.

### Working hard to ensure a high rate of material exchange

CUBG sits at the centre of one of the world's largest concentrations of researchers, and supporting third-party demand for plant material is central to our mission.



Horticulturist updating records using handheld device (Howard Rice).

Responsible, legal, transparent, and timely transfer of material and data is therefore a core principle of our work.

Over the past decade, we have expanded our capacity for national and international exchange. We established protocols, request forms, and material transfer agreements, and dedicated staff time to correspondence and facilitation. As a result, compared to the previous decade, we have increased the annual exchange of material by approximately 270% and our geographic reach by approximately 1200%. Over a quarter of the collection has been exchanged in some form or other, over the past 25 years.

Following the United Kingdom's exit from the European Union, new regulatory frameworks introduced significant logistical and financial challenges to international exchange, particularly with continental Europe. Despite these constraints, we remain committed to operating as an interconnected institution.

## Looking to the Future

After ten years of focused collections management, our team can look back with pride on many significant successes, but also with a degree of exhaustion. The management of living collections is demanding, and improvements are hard won, typically requiring a combination of technological innovation, cultural change, team building, and continual advocacy. In practice, we have found that we can sustainably re-engineer and embed only one or two major processes each year, and there remains much still to do. Our current challenge reflects this tension: we are securing an influx of exceptional, well-provenanced, rare and wild-collected material, but this success is creating bottlenecks across seed banking capacity, propagation expertise, plant establishment, and landscape decision-making. Living collections are often described as critical for *ex situ* conservation, yet achieving this role is not simply a matter of institutional or personal belief. Collections management at the level required to safeguard threatened species represents a substantial cultural, technological, infrastructural, and operational shift. And yes, high-quality, mobilised data are essential, if living collections are to realise their full potential.

## Four Core Principles

### Provenanced

The value of our collections are strongly shaped by provenance data, which we consider key indicators of living collections quality. For most stakeholders, plants sourced from the wild are most important. Other provenance categories, such as derived from wild, garden, or unknown, carry greater uncertainty, as data are at their strongest when recorded directly from wild-collected material. For these reasons, we aim to increase the proportion of wild-origin accessions in our collections, strengthening both the biological relevance of our plants and the reliability of their records. We place particular value on wild species that are rare in cultivation, as we believe these enhance our relevance within the botanic garden community.

### Integrated

The records we maintain are as central to the identity of our collections, as the plants themselves. They underpin all horticultural and curatorial work, enabling analysis, evaluation, and the continual improvement of the collections. We therefore strive to keep records that are robust, accurate, and consistent. Maintaining a strong and reliable link between plants and their associated data is fundamental to our work and is secured through multiple mechanisms, including labelling, mapping, audits, and verification processes. Subsequent integration of our data with global portals such as GBIF and BGCI Plant Search is a further essential step.

### Accessible

As a university botanic garden, one of CUBG's primary objectives is to support world-class research. As an active member of the global botanic garden community, we prioritise the sharing of plant material to advance research, learning, and *ex situ* conservation. We invest in making our collections highly accessible through comprehensive digitisation, transparent data sharing, and consistently rapid response times. Over the past decade, these efforts have enabled us to support more than 600 research projects worldwide at no cost to researchers. Accessibility actively shapes the development of our collections, guiding acquisition, curation, and stewardship of this shared resource.

### Sustainable

Sustainability means cultivating site-appropriate plants within the carrying capacity of the garden, not pursuing continual growth in collections size, but striving for balance. The management of our collections is increasingly predicated on present and future climate suitability, what we can grow now and what we are likely to sustain in the years ahead. We are researching the impacts of climate change on our collections to inform how we respond to these challenges while maintaining diversity. We aim to be intentional, integrating climate suitability into acquisition and de-accessioning decisions, reducing resource use, while maintaining the heritage value of our landscape.

## References:

- Brockington, S., et al. (2026). High-performance living plant collections require a globally integrated data ecosystem to meet twenty-first-century challenges. *Nature Plants* <https://www.nature.com/articles/s41477-025-02192-6>.
- Cano, Á., et al. (2025). Insights from a century of data reveal global trends in *ex situ* living plant collections. *Nature Ecology & Evolution*, 9(2), 214–224. <https://www.nature.com/articles/s41559-024-02633-z>.
- Mounce, R., et al. (2017) *Ex-situ Conservation of Plant Diversity in the World's Botanic Gardens*. *Nature Plants* 3: 795-802 <https://www.nature.com/articles/s41477-017-0019-3>.

**Sam Brockington, Ángela Cano and Margeaux Apple**

**Cambridge University Botanic Garden**

FEATURE ARTICLE

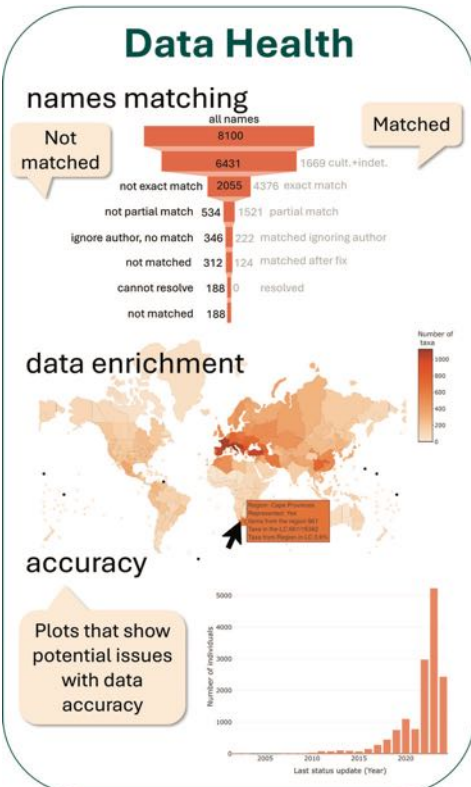
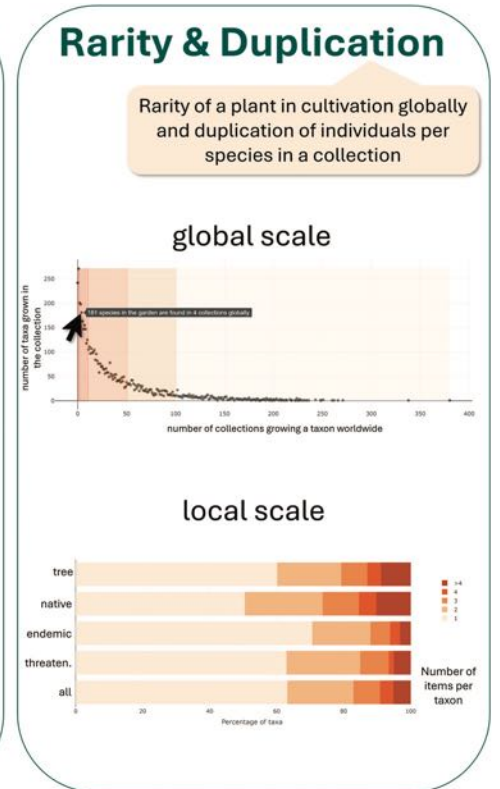
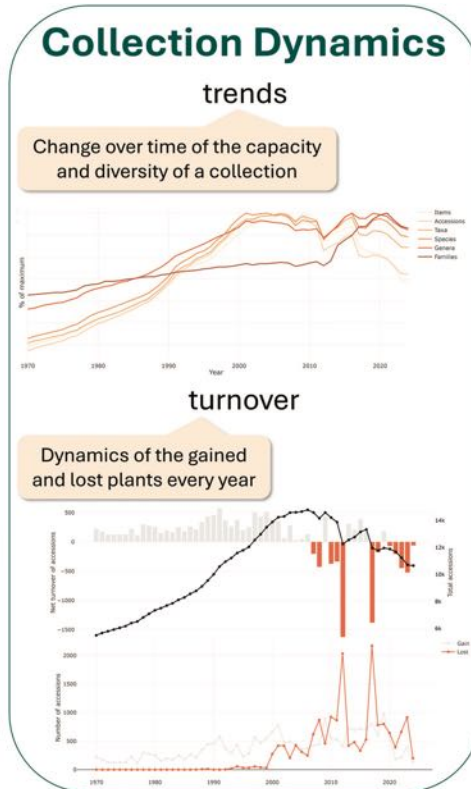
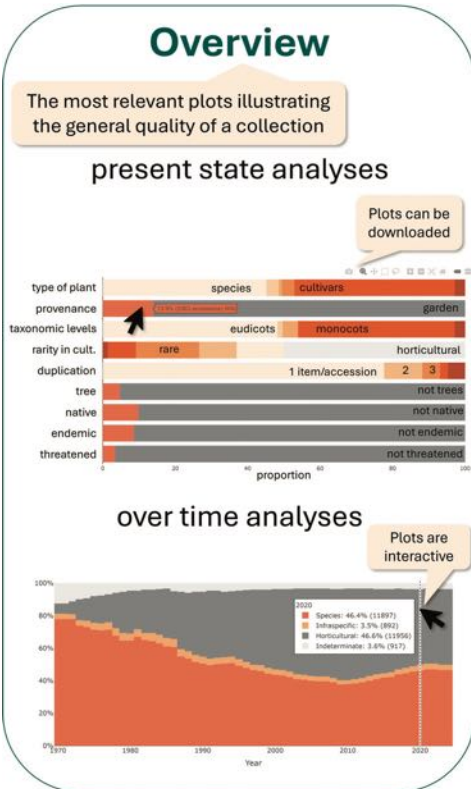

BGsmartR produces 11 interactive modules dedicated to different collection management themes.

# BGsmartR

BGsmartR is an informatic tool designed to support managers in their goal of keeping optimal living plant collections by revealing their dynamics over time and in the global context.

In essence, BGsmartR takes an export from a database and runs a series of automated analyses, focussing on collections quality and management, as a snapshot and over time. The process involves enriching the extracted report with updated information on taxonomic nomenclature, geographic distribution, conservation status, and more. The outputs from BGsmartR are strong and aesthetically pleasing interactive plots, as

well as management tailored spreadsheets, that managers can use to inform their practices and to communicate to their stakeholders. This tool will allow users to visualise the dynamics and the quality of their collections as often as they need to, to iteratively track the impact of policies and strategies on all their collections combined, or on specific horticultural sections.

BGsmartR was envisioned to empower collections managers and revolutionise their field by enabling high quality collections, capable of hosting thriving plant diversity and support successful ex situ conservation missions.

Any queries please contact the curation team at Cambridge University Botanic Garden ([curation@botanic.cam.ac.uk](mailto:curation@botanic.cam.ac.uk))

# PLANTSEARCH: A CONVERSATION WITH PETER WYSE JACKSON



Peter at the centre of the 2nd Global Botanic Garden Congress in Barcelona in 2004.

## INTERVIEW

Patricia Malcolm, Head of Membership and Conservation Services at BGCI, interviewed Peter Wyse Jackson on the origins of PlantSearch and the journey that shaped its creation



Peter's career began at Trinity College Dublin (Ireland), where he worked as the curator in its botanic garden, managing a small team of staff. It was there that he first encountered an IUCN publication, the first ever Red List of Threatened Plants and asked a simple but transformative question: *which of these threatened species are held in my garden?*

This early curiosity led him to recognise the fundamental role that botanic gardens could and should play in plant conservation. In 1985, he helped set up a propagation centre

for threatened native plants in Mauritius, making specimens of endangered plant species available for conservation, some of them for the first time. That experience proved pivotal, setting the course for a career dedicated to global plant conservation. From these beginnings, Peter went on to play a foundational role in establishing Botanic Gardens Conservation International (BGCI), and became its first Secretary General, before later becoming Director of the National Botanic Gardens of Ireland, and then President of the Missouri Botanical Garden (United States).

**Patricia: What problem in global plant conservation prompted you to create PlantSearch in the first place?**

**Peter:** To answer that, it's important to go back to the origins of PlantSearch, because its launch was really just one step in a much longer process to document and share information on living plant collections of threatened species in botanic gardens worldwide.

That process began in the 1970s, following a series of Plant Conservation Conferences held at the Royal Botanic Gardens, Kew. One outcome of those meetings was the development of the European threatened plant list, which was sent as a questionnaire to botanic gardens around the world by the predecessor of BGCI, the IUCN Botanic Gardens Conservation Co-ordinating Body. The simple request was to indicate which of the species it included were held in cultivation in each garden, and whether the material was of known wild origin or from cultivated sources.

Although basic, this exercise provided the first global insight into what botanic gardens were actually conserving. Over the following years, numerous questionnaires were circulated—focusing on threatened plants from many regions and island groups—and by the mid-1980s a computer-based database of more than 20,000 records had been assembled of threatened plants in botanic gardens.

At the same time in 1984, IUCN and WWF launched a global plant conservation programme, with one project specifically aimed at strengthening the role of botanic gardens in conservation. This became the topic of the first Global Botanic Gardens Congress that was held in the Canary Islands. The conference led to the establishment of an IUCN Botanic Gardens Conservation Secretariat, which I joined in 1987. A key part of our work was compiling and analysing data on threatened plants held in cultivation.

However, as I browsed through catalogues, guidebooks and documents it became apparent that information was being recorded in many different ways, often not electronically. This highlighted the need for a common International Transfer Format (ITF) for plant records, which was developed in the mid-1980s and

The screenshot shows the PlantSearch website interface. At the top, it says "Welcome to PlantSearch!" and lists languages: English (EN), En Español (ES), and 日本語で (JA). Below this, it states "The only global database of living plant, seed and tissue collections:" and lists key features: "Search 1,407,306 collection records, representing 557,444 taxa, at 1,118 contributing institutions" and "Locate threatened, rare, medicinal and other plant species in living collections". It also mentions "Connect with living collections to aid your conservation, education and research efforts".

The search criteria section includes:
 

- Scientific name: Three input fields for Genus, Species, and Infraspecific Epithet. A checkbox for "Exclude cultivar names" is checked.
- Conservation Status: IUCN Red List (dropdown menu set to "-- Please Select --").
- Additional Status: Crop Wild Relative (dropdown menu set to "Coffea"), Medicinal plant species (checkbox), CITES listed species (checkbox), and Threatened Global Trees Campaign species (checkbox).
- A link: "Which IUCN list should I choose?"
- A red "Search Plants" button.

Below the search criteria, it says "We found 183 matches" and displays a table with the following data:

#	Plant Name	Name Status	IUCN Red List	IUCN Red List 1997	CITES Appendix	Invasive Species Compendium fact sheet	CWR	No. of ex situ sites worldwide	Contact ex situ sites
1	<a href="#">Coffea ambongensis</a>	Accepted	-	-	-	-	✓	1	<a href="#">Send Request</a>
2	<a href="#">Coffea ambongensis</a>		-	-	-	-	✓	0	<a href="#">Send Request</a>
3	<a href="#">Coffea anthonyi</a>	Accepted	Vulnerable	-	-	-	✓	1	<a href="#">Send Request</a>
4	<a href="#">Coffea arabica</a>	Accepted	-	-	-	Look Up	✓	172	<a href="#">Send Request</a>
5	<a href="#">Coffea arabica var. abyssinica</a>		-	-	-	-	✓	1	<a href="#">Send Request</a>

PlantSearch's look in 2017.

still underpins most botanic garden record systems today. And all this information was put it into a system which was then launched on the Internet, and then botanic gardens were encouraged to contribute their data sets electronically; this work was led by Diane Wyse Jackson. The gardens were supported and encouraged to develop electronic data systems for their living plant collections. At that time there were a number of important botanic garden plant record systems, such as BGBase which is still in operation, and BGCI itself developed BGRecorder – a freely available system, available in several languages which was given out and used by many botanic gardens around the world, often providing their first computer-based plant records systems.

PlantSearch emerged naturally from this long evolution, bringing together accumulated datasets and making them accessible through an online, global platform.

**Patricia: When PlantSearch was launched, did you imagine it primarily as a conservation planning tool, a collections-management resource, or something else?**

**Peter:** From the beginning, PlantSearch was fundamentally about conservation. One of BGCI's primary objectives was to create an international ex situ plant conservation network, and PlantSearch was - and still is - a key mechanism for supporting that.

It also served to encourage botanic gardens to build conservation-focused collections. Before this, aside from traditional seed exchange lists via the Index Seminum system, there was very little systematic sharing of information about what plants gardens actually held. PlantSearch helped change that by making collections visible within a global context.

**Patricia:** How has PlantSearch changed the way botanic gardens understand and coordinate their living collections worldwide?

**Peter:** PlantSearch has been part of a much broader reinvention of botanic gardens. If you look at how botanic gardens were defined in the 1960s, the emphasis was largely on public display and plant labelling. Conservation was not a core element.

Today, conservation is widely recognised as a fundamental part of what is a botanic garden. Documented living collections are central to that definition, and PlantSearch has been an important tool in helping to build and connect a global network of ex situ collections.

This became especially clear with the adoption of the Global Strategy for Plant Conservation (GSPC) by the Convention on Biological Diversity in 2002. For the first time, there were global targets for plant conservation, including conserving threatened plant species in ex situ collections. PlantSearch was essentially the only mechanism available to measure progress towards that target at a global scale.

**Patricia:** Can you point to a moment where PlantSearch clearly demonstrated its value for conservation action?

**Peter:** The adoption of the GSPC was a key moment. Once a target was set for ex situ conservation of threatened plants, there had to be a way to assess what was already in cultivation and where gaps existed. PlantSearch provided that capability and allowed meaningful monitoring of progress.

**Patricia:** What do you see as PlantSearch's greatest strength—and where does it still have limitations?

**Peter:** Its greatest strength is that it allows collection holders to assess the priority and importance of their own collections, while also demonstrating to the international community the depth, value, and collective strength of botanic garden collections as a conservation network.

It has also provided a means or an impetus for individual botanic gardens to invest more seriously in plant record systems and to expand their collections to include species that had not previously been conserved through cultivation or in seed banks.

I think it has played a fundamental important role in achieving a lot of plant conservation objectives and continues to do so.

The main limitations are linked to capacity. The botanic garden community is incredibly diverse, ranging from very small institutions with just a few staff to large organisations with substantial resources. Not all gardens have the capacity to develop sophisticated record systems or conservation programmes.

The challenge has been to ensure that every institution, regardless of size, can play a meaningful role aligned with its own priorities. Despite this, the growth of the sector has been remarkable: the number of botanic gardens worldwide has quadrupled over the past four decades, driven in large part by increased recognition of their conservation role.

**Patricia:** Looking ahead, how do you see PlantSearch contributing to the next phase of global plant conservation?

**Peter:** Progress needs to be thoughtful and inclusive. There is no value in moving quickly if large parts of the community are left behind. We need systems that are accessible to all botanic gardens that wish to participate, and that can be sustained over the long term.

You know the old expression: How do you eat an elephant? And? And the answer is one bite at a time. And I think that is absolutely don't bite off more than you can chew. And I think everybody going forward needs to do that. And the way that we will do that will be by holding hands and going forward together.

**Patricia:** What advice would you give to the next generation of botanic garden leaders working at the intersection of science, data, and conservation?

**Peter:** Know your limitations and set up systems that support what you realistically need. Set targets, but don't try to do everything at once. Bring people with you and make conservation a core part of your institution's mission, supported and understood by stakeholders.

Start small if necessary, keep good records, and focus on work that will genuinely make a difference—ideally at a national or regional level. Avoid short-term projects that collapse once funding ends, and share resources and draw on the experience of others.

**Patricia:** If you had to summarise the importance of PlantSearch in one sentence for someone outside the botanic garden community, what would you say?

**Peter:** PlantSearch is the only comprehensive, fully accessible, worldwide, documented source of knowledge on what plant species are in cultivation in botanic gardens, in support of plant conservation.

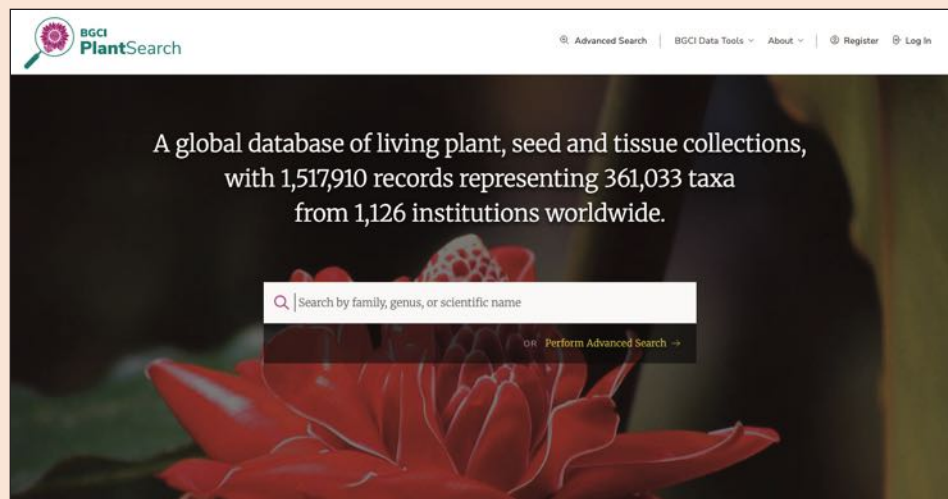

PlantSearch's present-day look.

# BOTANICAL SOFTWARE

Accessioning is the process by which plant acquisitions are formally recorded as permanent, traceable records within a botanic garden collection. Each accession represents plant material of a single taxon and propagule type from the same source and time, and is assigned a unique identifier. The accession register forms the official record and foundation of the collection.

Modern computerised collection management systems integrate databases, mapping and online or standalone access, and are chosen according to institutional needs, resources and long-term capacity. These systems often include technical support, training, upgrades and mobile compatibility. A range of widely used commercial botanical database software packages is available and listed below, although this list is not exhaustive.

## BG-BASE



Initiated in 1985 at The Arnold Arboretum, BG-BASE is the longest-tenured software in use around the world for botanical garden and arboreta collections management. The system consists of four modules: Living Collections (plant records), Preserved Collections (herbaria), Conservation (assessments), and ArcGIS/SQL Connector (mapping - co-developed with Blue Raster, [blueraster.com/capabilities/gis-mapping-for-public-gardens](http://blueraster.com/capabilities/gis-mapping-for-public-gardens).) Living Collections is the most widely used module, which includes inventory control, labeling, propagations, seed banking, image management, and horticultural tasks (pruning, fertilizing, etc.). Each new installation includes one year of technical support and a minimum of six hours of live, online training. Desktop, network, and cloud versions are available.

[www.bg-base.com](http://www.bg-base.com)

## BRAHMS



BRAHMS development started around 1990 with an initial focus on taxonomic research and herbarium management but then broadening out to manage botanic gardens and seed banks. BRAHMS is now deployed globally with projects ranging in size from the taxonomic revisions of small genera to managing some of the world's largest botanic gardens. The garden management components, developed collaboratively with RBG Kew, The Royal Horticultural Society (RHS), The Morton Arboretum, Chicago Botanic Garden and Singapore Botanic Gardens, cover all aspects of garden accession management and plant exchange. BRAHMS is delivered with inbuilt mapping, reporting and online publishing tools.

Example projects are listed on <https://herbaria.plants.ox.ac.uk/bol/brahms/software/aboutbrahms>

## IrisBG



IrisBG is a living collection management system developed through sustained collaboration with botanical gardens since 1996. It supports detailed accession histories with media, taxonomic validation, georeferenced mapping, field-based workflows, and more.

We facilitate collection activities, including accessioning, plant exchange, tour development, and tracking material over time. IrisBG integrates with standards and systems used by the botanical community: Darwin Core, ArcGIS, and BGCI data initiatives, enabling reliable data exchange and reporting.

[Our engaged global user community](#) contributes expertise and continuous feedback through initiatives such as [free monthly Coffee Chats](#). Learn more, schedule a demo, or request a free trial at [irisbg.com](http://irisbg.com).

## Botalista



Botalista is a platform based on the open-source philosophy and

dedicated to managing living botanical collections. Developed collaboratively with botanic gardens in Switzerland, France and Belgium, it offers a unified and continuously improving ecosystem covering accessioning, nomenclature (following the World Flora Online), horticultural tracking, seed banks, DNA storage, inventories, mapping and reporting.

Its modular architecture allows each institution to activate only the features it needs, while benefiting from shared development and transparent, community-driven governance. Botalista strengthens documentation quality, supports conservation strategies and ensures long-term data accessibility. With a growing European community, it promotes cooperation, shared standards and knowledge exchange.

<https://botalista.community/>

## Hortis



At Hortis, we believe botanic gardens are defined

by the value of their collections - but that value is only realised when the data is accessible and reliable. Our mission is to eliminate the friction of traditional record-keeping by providing a modern platform that empowers gardens of all sizes. We streamline workflows to help safeguard institutional knowledge so you can focus less on managing systems and more on reaching your targets.

If you're ready to increase your impact and reduce the effort of tracking your collections, join our fast-growing community of institutions that have already embraced a more collaborative, modern approach to collection management.

[www.hortis.com](http://www.hortis.com)

## Persephone 2.0



First developed by Plant Heritage in 2013 for recording the National Plant Collections®, Persephone

2.0 (launched 2022) has grown into a trusted online system for recording the plants in any garden, anywhere. With a steadily expanding subscriber base, it is designed to be intuitive for volunteers while remaining powerful and flexible enough for professionals working in large or complex gardens. Key features include robust synonym management, tracking of nomenclature changes over time, standard plant and accession fields, and customisable note fields. Users can also generate tailored reports and exports.

Visit <http://persephone.plantheritage.org.uk> or email [persephone@plantheritage.org.uk](mailto:persephone@plantheritage.org.uk) to arrange a demo and trial collection.

# ARTICLES

## DATABASES

**U-PLANT: AN OPEN-SOURCE DOCUMENTATION SYSTEM TO SUPPORT LIVING PLANT COLLECTIONS IN BOTANIC GARDENS**

**JARDÍN BOTÁNICO DE LA CIUDAD DE BUENOS AIRES “CARLOS THAYS”:  
AN EXPERIENCE IN DATABASES**

**A NOVEL PARADIGM FOR PLANT INFORMATION MANAGEMENT AT  
XISHUANGBANNA TROPICAL BOTANICAL GARDEN**

**RECONNECTING KEW’S BOTANICAL COLLECTIONS**

**ANALYSIS OF THE FUNCTIONS OF THE SHANGHAI CHENSHAN BOTANICAL  
GARDEN LIVING PLANT MANAGEMENT SYSTEM**

## DATA AND COLLECTION POLICIES

**AN UPDATED LIVING COLLECTIONS POLICY AT THE GENEVA BOTANIC GARDEN**

## IN SITU AND EX SITU CONNECTIONS

**THE ANDAMAN PLANT BIOREPOSITORY STRENGTHENS LIVING COLLECTIONS  
AND DATA SHARING**

**THE LIVING PLANT INFORMATION SYSTEM POWERS COMPREHENSIVE  
CONSERVATION ACTIONS FOR *MAGNOLIA ZENII***

**ADAPTING A LIVING COLLECTIONS MANAGEMENT SYSTEM FOR  
GLOBAL *EX SITU* CONSERVATION**

## THE POWER OF NETWORKS

**LIVING COLLECTIONS, DATA AND BOTANIC GARDENS’ NETWORKS:  
STRENGTHENING CONSERVATION HORTICULTURE THROUGH TRAINING**

# U-PLANT: AN OPEN-SOURCE DATABASE TO SUPPORT LIVING PLANT COLLECTIONS IN BOTANIC GARDENS



Figure 1: Poster session at EUROGARD X (Rome, September 2025) introducing the open-source release of the database U-Plant to the botanic garden community. From left to right: Pietro Picconi, Marco D'Antraccoli and Alessio Mo.

**U-Plant is an open-source database developed at the Botanic Garden and Museum of the University of Pisa to support the management and dissemination of living plant collections. Designed around principles of interoperability, clarity and public engagement, it provides curators and horticultural teams with a robust internal database while offering visitors an integrated web platform (U-Plant DISCOVER). This article outlines the database architecture, key functionalities, and early outcomes from its implementation, and highlights how open-source approaches can strengthen networking, transparency and long-term sustainability across the global botanic garden community.**

## Introduction

Botanic gardens and arboreta play an essential role in conservation, research, education and public awareness of plant diversity. Accurate and interoperable documentation of living collections is vital to fulfil this institutional mission (Wyse Jackson & Sutherland, 2000). In recent decades, several robust and reliable commercial systems (e.g., BG-BASE, BRAHMS, IrisBG, Hortis) have supported botanic gardens in the documentation and management of plant collections. However, fully open-source alternatives tailored to the operational needs of living plant collections remain scarce, creating barriers for gardens seeking cost-effective and customisable solutions. To address this gap, the Botanic Garden and Museum of the University of Pisa developed U-Plant, an open-source documentation database (Figure 1) that integrates internal collection management with a public-facing interpretative web portal. First designed in 2018 and adopted operationally in 2020 (Figure 2a), U-Plant aims to provide a robust, flexible and cost-effective solution for botanic institutions seeking to document, track, interpret and share information on their living collections. This article presents the conceptual foundations, structure (Figure 2b) and functionalities of U-Plant, discusses early outcomes from its implementation at the Botanic Garden of the University of Pisa, and highlights opportunities for wider adoption across the global botanic community.

## Why a new approach to plant documentation was needed

Until about five years ago, the documentation workflow adopted at our Botanic Garden presented several limitations. It was articulated in multiple, often temporally disconnected steps and relied on a clear separation between field activities (e.g., horticultural operations, plants labelling) and database management.

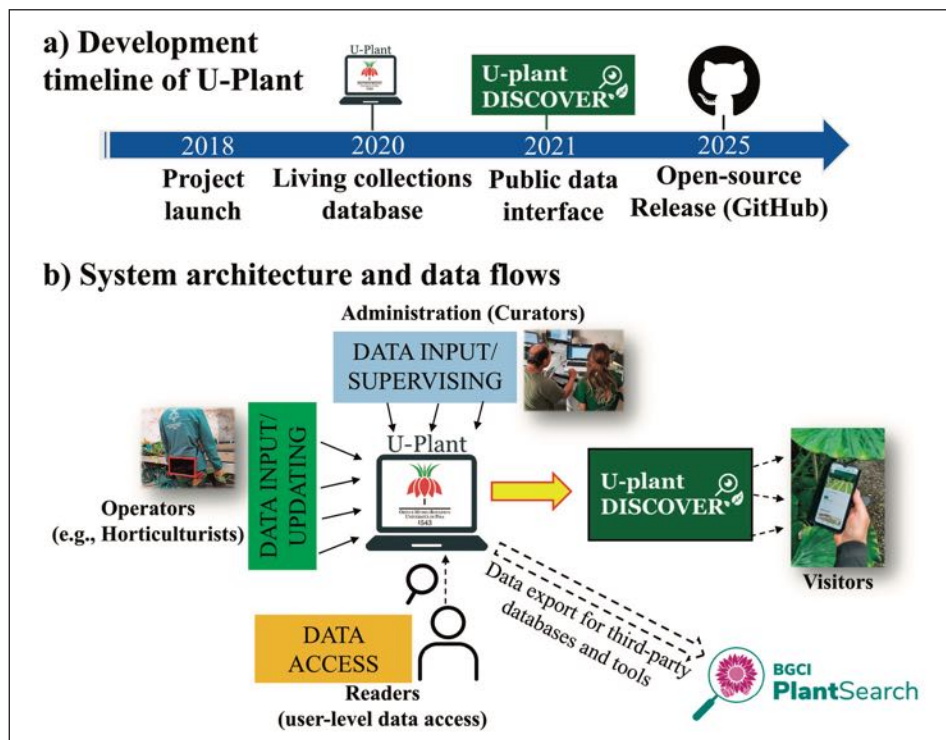

Figure 2: Development timeline and system architecture of U-Plant. (a) Timeline illustrating the main development milestones of U-Plant, from project launch in 2018 to the release as an open-source platform in 2025 (b) Conceptual architecture and data flow of the U-Plant system. Curators manage administration, data input, and supervision/validation, while operators (e.g., Horticulturists) contribute to data input and updating in the field. U-Plant acts as the central hub for data management, supporting both internal users with read-only access and external users through the public interface (U-Plant DISCOVER). The system is designed to enable data export to third-party databases and tools, such as BGCI PlantSearch, facilitating interoperability and data reuse.

Additionally, documentation tasks were frequently perceived as secondary rather than as a core component of collection curation. Accession records were initially compiled on paper and only transferred to a database after variable periods of time. Once the entries were recorded, the absence of clearly defined procedures for subsequent updates – considering the high dynamicity of living plant collections – determined that the database was often misaligned with the actual situation in the garden, progressively reducing its reliability. In addition, the presence of poorly adapted or unfriendly data fields encouraged an excessive use of generic “Note” fields, further limiting data standardisation and opportunities for data export. These critical elements were further amplified by the limited availability of curatorial staff time, constrained both by staff shortages and by the need to fulfil multiple additional institutional functions. In this context, a fragmented and time-consuming documentation system proved unsustainable. We therefore redesigned the workflow by deliberately extending documentation responsibilities beyond the curatorial domain, for example by actively involving

horticultural staff from the earliest stages of the process. An optimised and codified documentation workflow was developed, starting from the daily activities of horticulturists and integrating their observations and actions into a single, shared digital tool. While roles and responsibilities remain clearly differentiated, all staff members converge on one continuously updated source of information, supervised by the Administrators of the database. Documentation is thus reframed as a shared and collective practice across the entire botanic garden staff (Figure 2b).

### Development principles and rationale

U-Plant was designed around three guiding principles that reflect the operational and educational needs of contemporary botanic gardens. First, ‘Interoperability and Collaboration’: the documentation and fruition of living collections is inherently multidisciplinary, involving curators, taxonomists, horticulturists and educators. U-Plant’s architecture mirrors this collaborative reality by defining three credential levels: Administrator, who edits

core information, validates accession records, manages administration tables and ensures overall data coherence; Operator, who enters accession and enter/update individual records; and Reader, who can access full records without editing rights (Figure 2b). This tiered structure supports shared responsibilities while maintaining data integrity and aligns with internationally recognised documentation frameworks. Second, ‘Simplicity and Clarity’: many gardens, especially small- to medium-sized institutions, struggle with overly complex datasets and rigid workflows. To promote consistent and accurate data entry, U-Plant prioritises intuitive interfaces, controlled vocabularies and a clear distinction between mandatory and optional fields. Essential documentation elements required by international standards are preserved, but redundancy is reduced, allowing users to focus on high-value information without dispersing working efforts. Third, ‘Connecting Curatorial Data with Public Engagement’: a distinctive feature of U-Plant is its dual identity as both an internal management system and a public-facing portal. U-Plant DISCOVER retrieves real-time data from the database and translates it into accessible content for visitors and educators. This responds to the growing emphasis on interpretation and community engagement within botanic gardens (Williams et al. 2015; D’Antraccoli et al. 2023). Through the proposal of thematic visits, georeferenced maps and bilingual specimen profiles, U-Plant DISCOVER turns curatorial data into collections’ valorisation and meaningful learning experiences, strengthening the role of gardens as centres of education and outreach.

### Database system architecture

The system is available in two languages, English and the national language of the botanic garden adopting U-Plant. The source codes are available on the GitHub repository <https://github.com/Unipisa/U-Plant>. The two main levels of the database are ‘Accessions’, documenting new entries into the collection and ‘Individuals’, representing specimens belonging to a given accession which have a definite and distinct physical location in the botanic garden. Accession codes are assigned automatically following the standard format YEAR-progressive number, while individuals nested within each accession receive sequential numbers after the accession code (i.e., YEAR-progressive number/0001, ...).

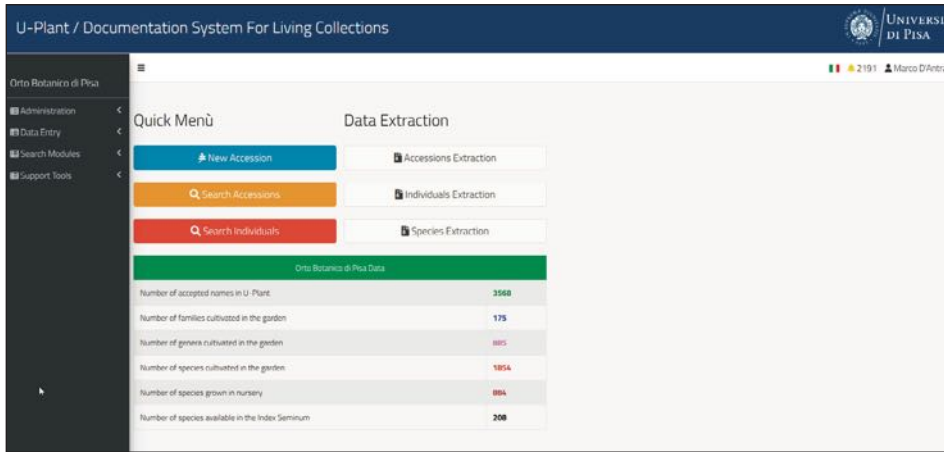

Figure 3: Homepage of the U-Plant database. The interface includes a left-hand panel providing tools for the management and entry of primary data into the database (structure tables), along with shortcut options for adding new accessions, querying records, and accessing data export utilities. At the bottom of the homepage, a summary table displays key statistics of the collections managed by the Botanic Garden. The layout and available functionalities vary according to user permissions; the interface shown corresponds to the Administrator view.

The homepage of U-Plant (Figure 3) serves as the primary entry point and features a left-hand panel with tools for managing core database content via Administration tables (accessible only to users with Administrator credentials), entering new accessions, running basic and advanced queries, and accessing Support Tools. The central area provides a shortcut menu for rapid access to key functionalities, while a summary table at the bottom displays collection-level statistics. The accession entry module is divided into five sections: 1) Taxonomic Identity, 2) Details (e.g., Acquisition Date, Acquisition Mode, Material Origin, Material Type, IPEN code and other controlled fields), 3) Sampling Data (in

case of wild collected material), 4) Acquisition Data (e.g., Donor/Supplier, Collector, Identifier) and 5) Additional Data (Notes, Associated Herbarium specimens and optional metadata) (Figure 4). Allow users to perform queries based on the following criteria, either individually or in combination: Taxonomy, Accession code, IPEN code, Material type, Acquisition Mode, Acquisition Date ranges, Taxonomic uncertainty, Collector and Donor/Supplier. Each individual plant (Figure 5) is documented through a dedicated form comprising: 1) Main Data (Propagation Date, Propagation Method, and Sex when applicable), 2) Location in the Botanic Garden (Sector, Collection, Label, coordinates, and georeferencing on em-

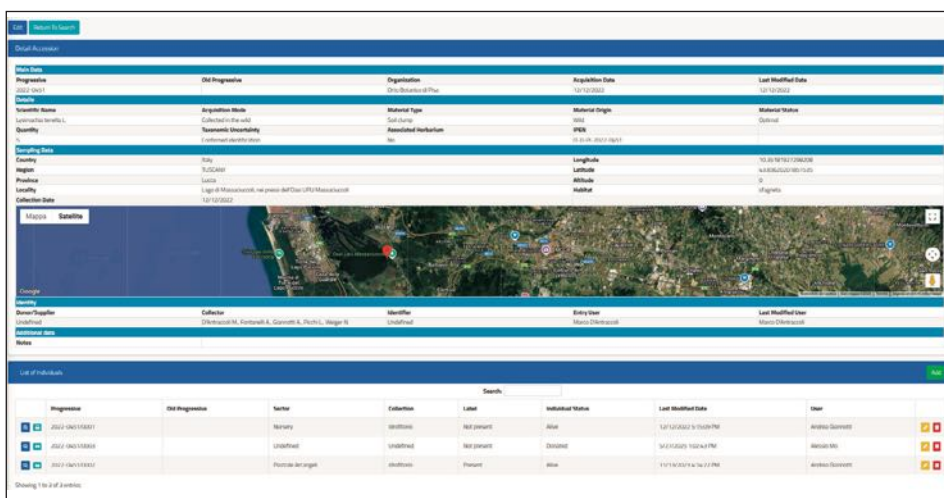

Figure 4: Accession record interface of the U-Plant database (accession progressive number 2022-0451). The accession record aggregates core information, including the scientific name and identification details, acquisition method, material provenance, and collection data for wild-origin accessions. A list of the individual specimens associated with the accession is displayed at the bottom of the interface.

bedded maps), 3) Current Situation – Individual Status (e.g., Alive, Dead, Uncertain, Available, Out of Stock), health assessment, and a free-text field for Horticultural Operation. A chronological table ('Individual Record History') stores all horticultural updates, improving long-term traceability. A photo gallery allows staff to upload images linked to each individual, with optional visibility settings for the public-facing portal. Search tools enable filtering by taxonomic identity, Sector, Collection, Individual Status, Condition, Label or Propagation Date ranges.

### *Open-source development lowers economic barriers and empowers institutions with limited financial resources.*

#### The public portal: U-Plant DISCOVER

U-Plant DISCOVER (<https://uplantdiscover.sma.unipi.it/>) is a web portal that displays real-time information to the public on all individuals marked as "Alive" in U-Plant. Key functionalities include Basic and Advanced search (Scientific Name, Family, Common Name, Floristic Kingdom, Sector or Collection); each Individual specimen page (Figure 6) provides comprehensive information, including taxonomic identity, provenance, acquisition mode, a georeferenced map to support way-finding, and curated image galleries. In addition, a "Send us your photo" feature enables the collection of visitor-generated content, fostering engagement and participatory documentation. A dedicated section, managed directly within U-Plant, offers both permanent and temporary thematic visits focused on topics such as biogeography, veteran trees, and seasonal flowering (Figure 7). The page also features a gallery showcasing the four most recently planted individuals in the garden. Over the past year (September 2024 – September 2025), DISCOVER was used by an estimated 2% of total visitors to the garden (D'Antracoli et al., in review), a modest but encouraging result considering limited promotion. Preliminary feedback suggests strong potential in guided thematic tours, school programmes and targeted interpretative displays.

### *U-Plant DISCOVER connects visitors with real-time data from living collections, supporting education and interpretation.*

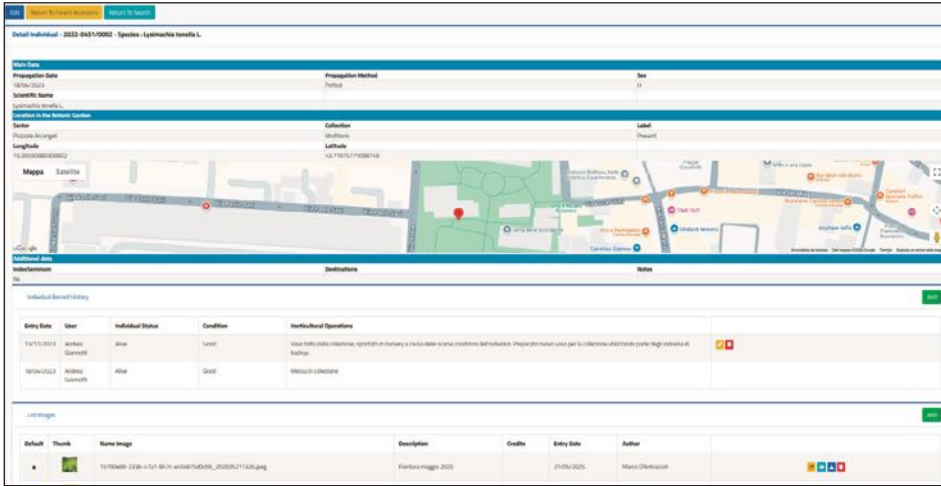

Figure 5: Individual record interface of the U-Plant database (Individual progressive number 2022-0451/0002). The upper section presents specimen-level information, including main descriptive data and the location within the Botanic Garden, supported by an interactive map. The central section documents the individual's record history, while the lower section provides access to the photographic documentation linked to the specimen.

## Benefits for the Botanic Garden community

U-Plant addresses several challenges commonly faced by botanic gardens worldwide (Gratzfeld 2016), providing a practical and flexible solution for living collection management. A key advantage is cost-effectiveness and long-term sustainability. Unlike commercial systems that require licensing fees and ongoing subscriptions, U-Plant is fully open-source, eliminating financial barriers and ensuring independence from vendors. This model is particularly beneficial for smaller gardens and institutions

in low-resource contexts, supporting global equity in plant conservation. The system also promotes transparency, and customisation. Open access to source code and database structures allows institutions to adapt the platform to their specific workflows, strengthen reproducibility in research, and ensure that institutional knowledge can evolve alongside changing priorities. Interoperability and potential networking represent another major benefit. U-Plant's hierarchical architecture is designed to facilitate future inter-institutional data exchange. U-Plant facilitates data extraction for use in global platforms like BGCI

PlantSearch (Figure 2b), promoting interoperability with other institutions, datasets and tools (Holetschek et al. 2019).

## What's next?

Like all open-source initiatives, the U-Plant project plans to rely on sustained community engagement, technical maintenance, and institutional commitment. Its development roadmap includes several priorities: automated taxonomic validation via World Flora Online (<https://www.worldfloraonline.org/>) or Plants of the World Online (<https://powo.science.kew.org/>); Darwin Core-compliant data exports, improved tools for mobile data entry and image uploads by visitors; dedicated modules for tree management, analytical tools to assess collections trends/statistics, and Index Seminum catalogue draft. Collaboration with other gardens will be crucial for success. By fostering a shared open-source ecosystem, U-Plant offers significant potential for co-development, mutual support, and increased impact at wider scales, ultimately enhancing the management, accessibility, and educational value of living plant collections.

*U-Plant provides a transparent, adaptable and community-driven alternative to proprietary plant documentation systems.*

## Conclusions

U-Plant aims to demonstrate how an open-source, transparent and adaptable database can strengthen the curation, traceability and interpretation of living plant collections. By integrating an internal management platform with a real-time public interface, U-Plant simultaneously strengthens curatorial workflows and enhances the institution's educational outreach. As botanic gardens increasingly contribute to global conservation challenges, shared and sustainable digital infrastructures such as U-Plant have the potential to enhance collaboration and amplify the value of living collections at a wider geographic scale. We encourage botanic gardens worldwide to explore, adopt and contribute to U-Plant, supporting a community-driven approach to documenting and interpreting the world's cultivated plant diversity in ex situ plant collections.

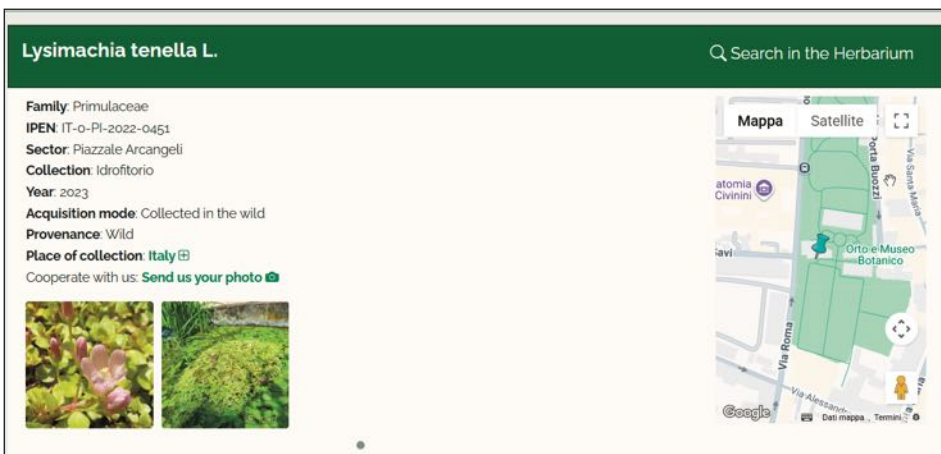

Figure 6: Web interface of U-Plant DISCOVER showing accession information for an individual cultivated in the Botanic Garden. The record presents taxonomic data and collection details. The plant's current location within the garden is displayed on the interactive map on the right. The "Send us your photo" function allows users to submit images of cultivated specimens directly to Botanic Garden staff. At the bottom of the page, a photo gallery is shown.

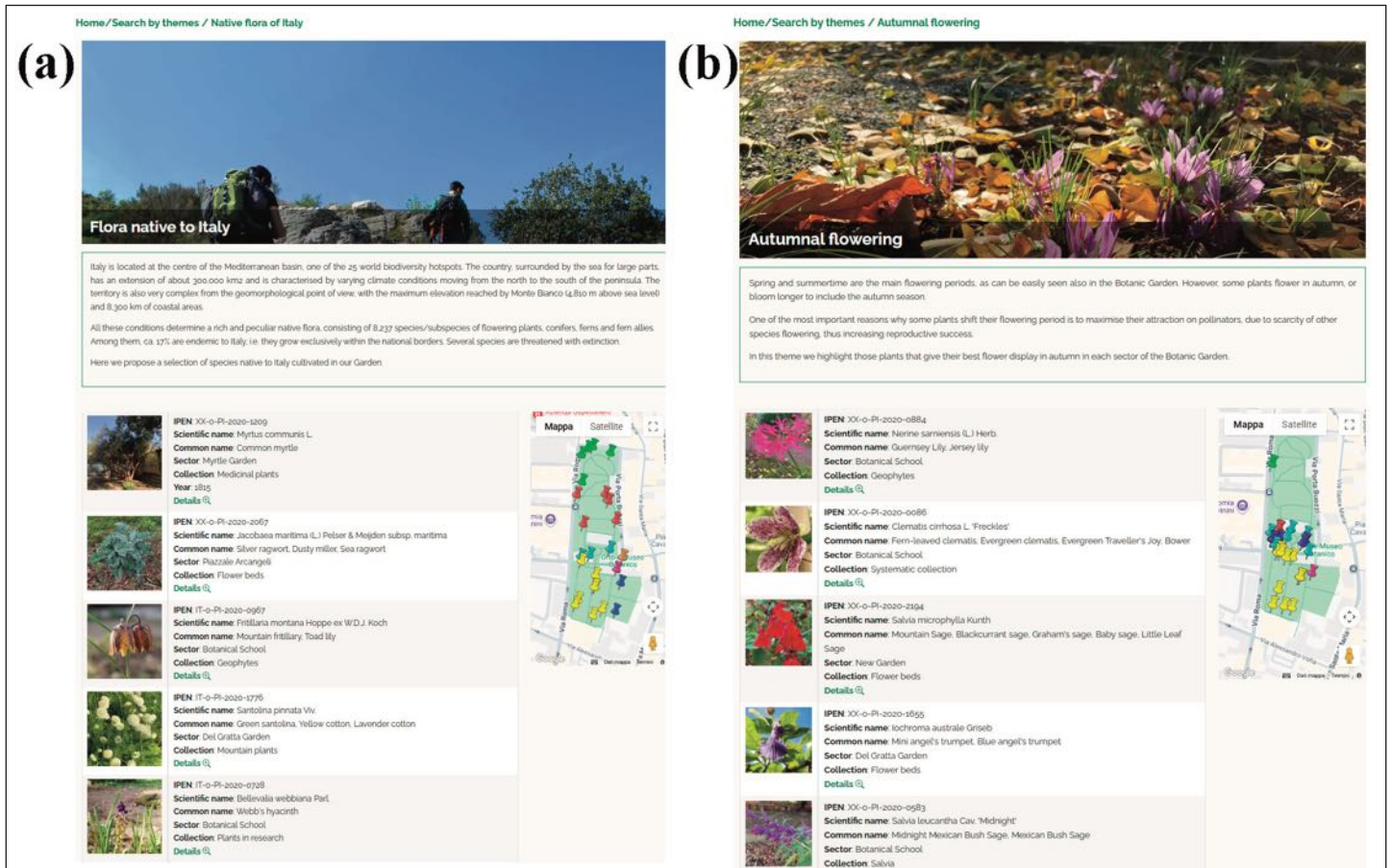

Figure 7: Example of a couple of thematic visits in U-Plant DISCOVER. The interface includes a title, a brief description, a curated list of selected individuals within the Botanic Garden, and a map indicating their locations. The examples shown are (a) the permanent thematic visit “Flora Native to Italy” and (b) the seasonal visit “Autumnal Flowering”, which is available only during its designated active period.

## References

- D’Antraccoli, M., Carta, A., Astuti, G., Franzoni, J., Giacobbe, A., Tiburtini, M., Pinzani, L., & Peruzzi, L. (2023) A Comprehensive Approach to Improving Endemic Plant Species Research, Conservation, and Popularization. *Journal of Zoological and Botanical Gardens* 4, 490-506.
- D’Antraccoli, M., Picconi, P., Maccioni, G., Borgioli, D., Mo, A., Peruzzi, L. (in review) U-Plant and U-Plant DISCOVER: An Open-Source Database for Botanic Garden Collections Management and Public Engagement.
- Gratzfeld, J. (Ed.), 2016. From Idea to Realisation – BGCI’s Manual on Planning, Developing and Managing Botanic Gardens. Botanic Gardens Conservation International, Richmond, United Kingdom.
- Holetschek, J., Droege, G., Güntsch, A., Köster, N., Marquardt, J., Borsch, T. (2019) Gardens4Science: setting up a trusted network for german botanic gardens using open source technologies. *Biodiversity Information Science and Standards* 3, e35368.
- Williams, S.J., Jones, J.P.G., Gibbons, J.M., Clubbe, C. (2015) Botanic gardens can positively influence visitors’ environmental attitudes. *Biodiversity and Conservation* 24, 1609–1620.
- Wyse Jackson, P.S. & Sutherland, L.A. (2000) International Agenda for Botanic Gardens in Conservation. Botanic Gardens Conservation International, Richmond, United Kingdom.
- Alessio Mo, [alessio.mo@unipi.it](mailto:alessio.mo@unipi.it), Assistant Curator, Botanic Garden and Museum of the University of Pisa, via Ghini 13, I-56126, Pisa (Italy)
- Pietro Picconi, [pietro.picconi@unipi.it](mailto:pietro.picconi@unipi.it), University Informatic System, University of Pisa, Lungarno Pacinotti 43/44, I-56126, Pisa (Italy)
- Daive Borgioli, [davide.borgioli@unipi.it](mailto:davide.borgioli@unipi.it), University Informatic System, University of Pisa, Lungarno Pacinotti 43/44, I-56126, Pisa (Italy)
- Lorenzo Peruzzi, [lorenzo.peruzzi@unipi.it](mailto:lorenzo.peruzzi@unipi.it), Director, Botanic Garden and Museum of the University of Pisa, Department of Biology, University of Pisa, via Derna 1, I-56126, Pisa (Italy)



## JARDÍN BOTÁNICO DE LA CIUDAD DE BUENOS AIRES “CARLOS THAYS”: AN EXPERIENCE IN DATABASES

The challenge for botanic gardens when recording their data is finding a software tool capable of adapting to new questions.

The possible solutions range from using third-party applications, which implies a certain rigidity due to the difficulty of making modifications, to highly flexible solutions, which translates into more time spent compiling quality records.

Data science offers a more effective alternative; developing a custom application, with the advantages of automation and flexibility tailored to the specific requirements. In this article we provide the experience of the “Carlos Thays” Botanic Garden in Buenos Aires.

### Our experience, why a new database system was needed?

While botanic gardens (BGs) share the same goal of conservation and engagement with visitors, their data recording criteria can vary considerably. Provided the existence of data, when sharing information the different criteria do not allow for comparison or obtain the necessary information. There are two main

reasons for these problems. One is the lack of standardised criteria among BGs. The other arises when the tool used to store the data is not appropriate.

Due to their flexibility and ease of use, spreadsheets like Microsoft Excel are often used for data storage, even though this is not their intended purpose, which inevitably leads to inconvenience. The appropriate technology for these requirements is databases, which

were specifically designed for this purpose. The obstacle to their use is the greater training required compared to spreadsheets. Furthermore, to fully utilise the potential of databases, it is necessary to develop applications to manage them. This means that to use this technology, you will need to obtain licenses for pre-designed applications, or develop your own, a much more complex but increasingly accessible task.

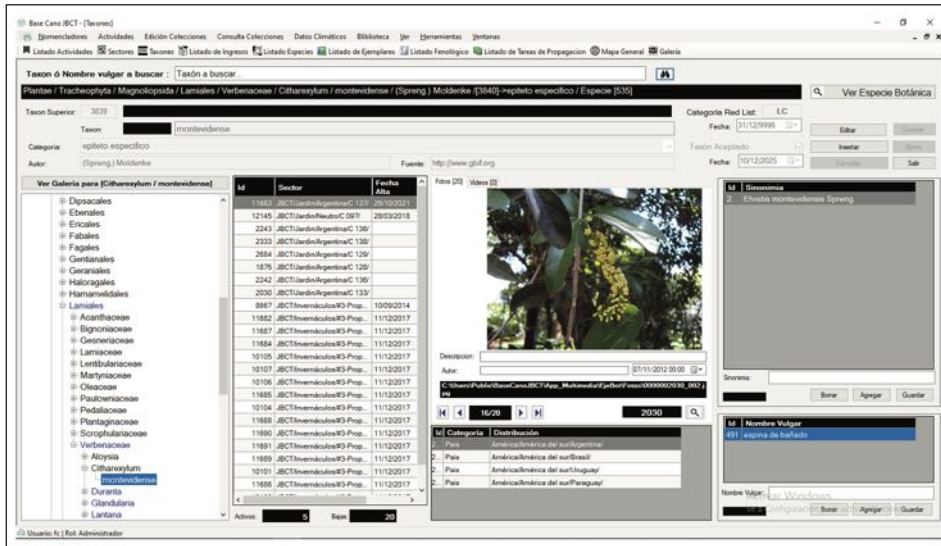

Figure 1: Screenshot of our application.

Fifteen years ago, the Carlos Thays BG of Buenos Aires decided to develop its own application, as opposed to using pre-designed applications or an ever-changing spreadsheet. The latter option was quickly discarded, and although third-party applications have their advantages, the lack of availability of the product in Spanish, along with the difficulties in making ad hoc modifications, among other factors, led us to that final decision.

### How does our system look today?

After implementing the first version in 2011, we have successively modified our application to improve the quality of our records. These modifications will certainly continue.

In Figure 1, the screenshot shows from left to right the taxon tree, a list of specimens of a given taxon, images of those specimens, the species' distribution (below the images), synonyms of the taxon, and common names.

This decision forced us to precisely define which data corresponds to our record objects. For the purpose of illustrating we will focus on four of the most important

objects: "Entrance," "Specimen," "Species," and "Propagation Task," and how their data relates to each other.

Generally speaking, relational databases are made up of "tables", which contain "fields". Data is stored within this structure. As an example, Figure 2 shows some of the "Entrance" table fields in columns.

It is important to mention that the tables and some of their fields can be related to each other. Figure 3 shows these relationships, taken from a brief model adapted from our database.

This simple schema should be interpreted to mean that a Specimen can correspond to an entry record or to a Propagation Task that originates it. In turn, a Propagation Task corresponds to an Entrance, and then the Specimen takes its scientific name (Taxon) from the Species table. The relationships between the Id and IdSpecimen fields in the Entrance and Specimen tables ensure a recursive process in which an Entrance can be created from a Specimen. Such would be the case of collecting seeds from one's own specimen.

These relationships fulfil the essential requirement of specimen traceability. Furthermore, a single Entrance whose Quantity is, for instance, 5, will correspond to 5 Specimens, each of them related to that single Entrance.

Note that the first record in Figure 2 can give rise to one or more records in the Propagation Task table and/or one or more records in the Specimens table. This is just one model, but it illustrates a logic applicable to countless variations.

Any of these fields, and others that can be added, can be included in a data query, which is ultimately necessary for analysis and decision-making regarding the collections. For example, it's possible to build datasets with the fields required by an external repository, such as BGCI's PlantSearch.

### What are the benefits of our system?

Only with reliable data is collection management more efficient:

- Knowing the quantity and age of all specimens of a species makes it easier to decide whether to remove a diseased specimen or try to improve its condition.
- Focusing on relevant species or families with only one specimen and reducing excess stock.
- Analysing successive Propagation Tasks allows for the definition of Propagation Protocols for species of interest.
- Analysing the evolution of collections over time.
- Data on the origin of specimens and their traceability allows for adding value to each specimen.

Id	Id Specimen	Collection date	Cientific Name	Type	Quantity	Latitude	Longitude	Altitude
1541	2561	2010-5-4	Monvillea euchlora	seed	50	S 27° 16,124'	W 55 °33,214'	15
1542	2562	2010-5-14	Sesbania punicea	seed	150	S 34° 22.115	W 58° 34.597	24

Figure 2: "Entrance" Table, Fields, and Data.

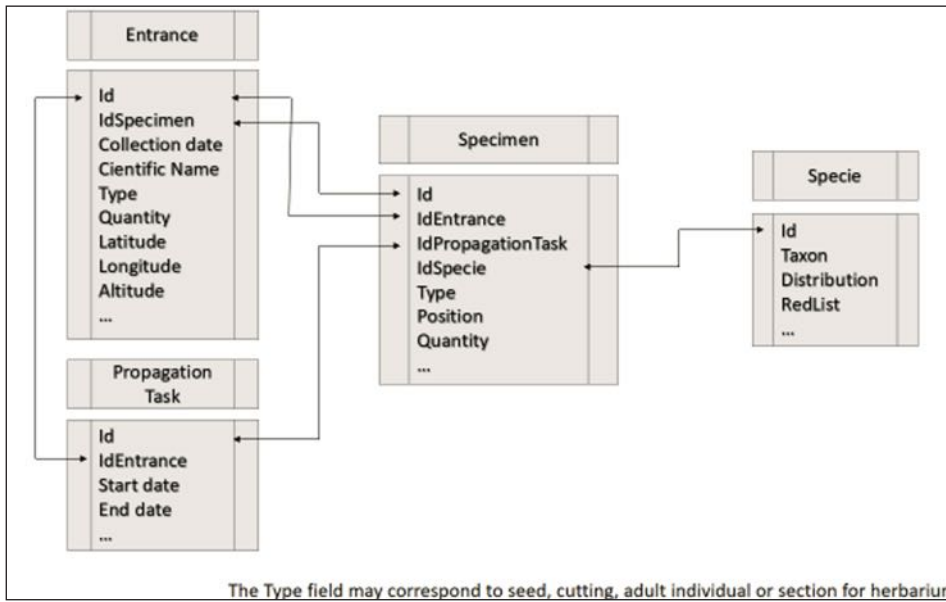

Figure 3: Related tables and fields.

At the Carlos Thays BG, this model has grown in tandem with the increasing demand for data. Phenology, health, events, bibliography, images, and other resources have contributed their structure and data to expand the information base, which is now consulted as fundamental information for research projects.

### What resources are needed to support such system?

It is essential to consider that for a BG to implement models of this type, certain resources must be accessed. Where budget and capacity allow the recruitment of a developer to oversee the use of a bespoke application is highly advantageous, although there may also be other roles within the existing team that have the skills to deliver. It could also be possible to train one or two existing staff members in programming languages and database design. Staff training in these technologies is becoming increasingly accessible, allowing for the invaluable possibility of creating in-house resources. It's certainly not an easy task, but the possibility of learning these technologies

is constantly growing (Darás de la Fuente, 2022). Another option is for several BGs' users to agree on a common application and hire a company or programmer to develop it.

Depending on the size of the BG, new roles will be necessary when incorporating this technology.

- A "business owner" will decide on the modifications to be implemented: when, how, and why they should be carried out.
- A data curator will ensure the quality and consistency of the uploaded data.
- Requests for new modifications can be "collected" by a coordinator.
- A system administrator will manage user additions and removals, database backups, and maintain the system running.
- Division of tasks: Some technicians may specialise in specific tasks. Validation against bibliography, scientific names, and species vulnerability categories, as

well as phenology, health, label production, and image production, could be specific tasks for certain technicians. This plays a crucial part in increasing the efficiency of working hours.

The requirements that any development of this type demands should not be forgotten. Developing a custom system means that at least one person must be dedicated to this task. Furthermore, the results are not immediate, since beyond the development time, a testing period is required to identify and correct the errors inherent in any innovation.

### Conclusions

The key advantage of developing a custom application is that the ability to modify both the code and the database structure ensures its versatility, security, data integrity, and portability. This prevents the application from becoming obsolete over time and improves the efficiency of technical staff in their office tasks by substantially reducing the time required for registration.

### References

- Darás de la Fuente, Claudia. Un estudio comparativo de los lenguajes de programación de la última década. 2022. Tesis Doctoral. Universitat Politècnica de València.

**Ing. Agr. Fernando Cano**  
Developer  
Jardín Botánico "Carlos Thays".  
frcano@buenosaires.gob.ar

**Ing. Agr. Mg. Sc. Graciela Barreiro**  
Head Manager  
Jardín Botánico "Carlos Thays".  
gmbarreiro@buenosaires.gob.ar

**Jardín Botánico "Carlos Thays".**  
Gobierno de la Ciudad de Buenos Aires. Av. Santa Fé 3951. Ciudad de Buenos Aires. Argentina.

# A NOVEL PARADIGM FOR PLANT INFORMATION MANAGEMENT AT XISHUANGBANNA TROPICAL BOTANICAL GARDEN



Figure 1: The Flowers Garden at Xishuangbanna Tropical Botanical Garden.

## Introduction

Plant information management systems constitute a core infrastructure for the scientific operation and conservation missions of botanic gardens. As global biodiversity conservation efforts intensify, botanic gardens face mounting challenges, including expanding collection scales, increasing complexity of data types, and growing demands for data interoperability and sharing. Conventional approaches to plant information management are increasingly inadequate for meeting the needs of modern botanic institutions.

The Xishuangbanna Tropical Botanical Garden (XTBG), Chinese Academy of Sciences, maintains over 13,000 species of living plants, making it one of the largest botanic gardens in China in terms of area, species diversity, and number of specialised thematic gardens. It also ranks among the world's leading botanic gardens in terms of the number of plant species conserved

Xishuangbanna Tropical Botanical Garden has developed an innovative plant information management system that enables efficient, full-lifecycle data management of living plant collections through automated accession registration, standardised workflows, streamlined operations, and unified data standards. A key innovation of the system is the implementation of “sticky\_code” technology, which links all data points—from initial collection to plant death—into a continuous, traceable chain. This approach provides a replicable model for digital management in botanic gardens worldwide.

outdoors and displayed to the public. To address the challenges posed by managing such vast and complex botanical data, XTBG initiated the development of a next-generation plant information management system in 2023, aiming to establish an efficient, intelligent, and standardised digital platform for plant collection management.

## Current Status of Plant Information Management Systems

Internationally, the development of plant information management systems (PIMS) spans several decades. The most representative example is BG-BASE, initiated in 1985 by the Arnold Arboretum of Harvard University.

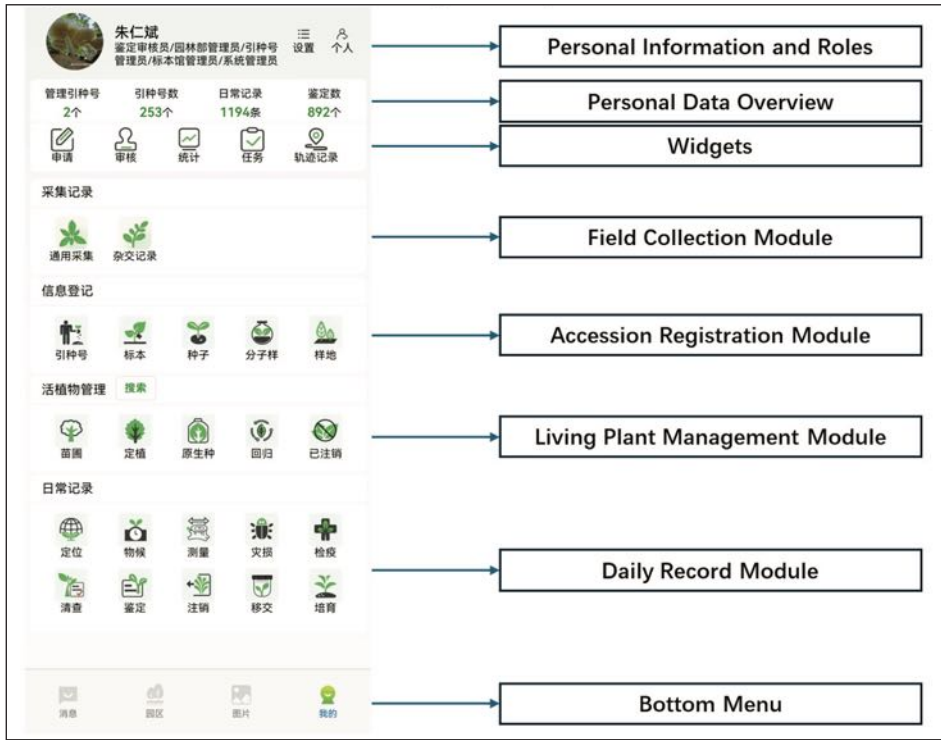

Figure 2: Mobile application interface of the XIMS.

Over time, BG-BASE has evolved into a comprehensive information management platform comprising 19 functional modules, including living collection management, herbarium specimen tracking, field expedition data, genetic databases, and flora and fauna survey records. By 2005, BG-BASE was in use at 175 botanical gardens worldwide.

In China, efforts toward botanical garden informatisation also began relatively early. For instance, in 1988, the Nanjing Botanical Garden (Sun Yat-sen Memorial) launched research on a “Computerised Management

System for Plant Germplasm Data,” and formally implemented a living plant information management subsystem in 1994. However, constrained by limited computing technology at the time, plant information management remained largely at the level of digitised record-keeping and did not evolve into an integrated digital system.

A significant turning point came in 2013 with the establishment of the Chinese Union of Botanic Gardens (CUBG). Led by the South China Botanical Garden, Chinese Academy of Sciences, CUBG spearheaded the nation-

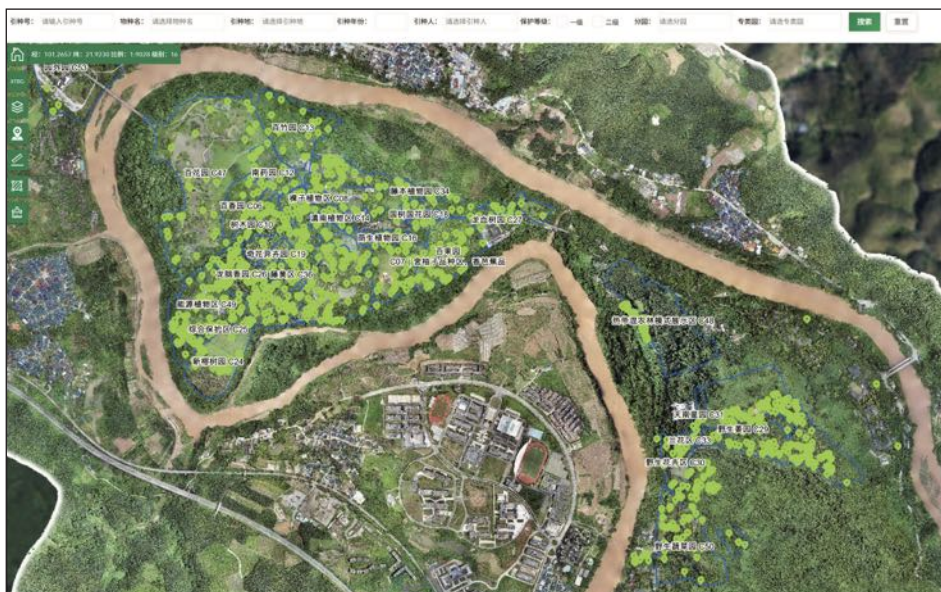

Figure 3: Web-based garden map interface of XIMS.

wide development and deployment of a standardised Plant Information Management System (PIMS), which was subsequently rolled out to 40 member botanic gardens. Despite its broad adoption, the PIMS platform has certain limitations and cannot fully meet the diverse operational needs of all institutions—particularly large, well-resourced botanic gardens. As a result, leading institutions such as Shanghai Chenshan Botanical Garden and Shanghai Botanical Garden have independently developed their own customized PIMS solutions tailored to their specific management requirements.

## Xishuangbanna Information Management System (XIMS)

### 1. Automated Introduction Registration

Users can complete the entire accession and registration process by simply uploading photographs of the collected plant material and entering minimal metadata. Key information—including collection date, location, accession number, and even preliminary taxonomic identification—is automatically generated using integrated algorithms and reference databases. This approach significantly reduces manual input while ensuring high data quality and consistency.

### 2. Standardised and Digitalised Management Workflow

The system integrates all stages of a plant's life cycle—from initial field collection through accessioning, nursery entry, permanent planting, maintenance, to scientific observation—into a unified, standardised digital workflow. Each step is accompanied by clear operational guidelines and structured data entry requirements. Critically, every new data record is automatically linked to its predecessor, creating a continuous, traceable data stream.

For example, once an accession is registered, a formal “transfer” action moves the plant record into either the nursery or a designated display garden. Based on this updated status, users can immediately initiate routine management activities—such as phenological monitoring, taxonomic revisions, morphometric measurements, or deaccessioning—directly within the system. This end-to-end integration enables fully digitised, process-driven management of ex situ conserved plants throughout their entire life cycle.

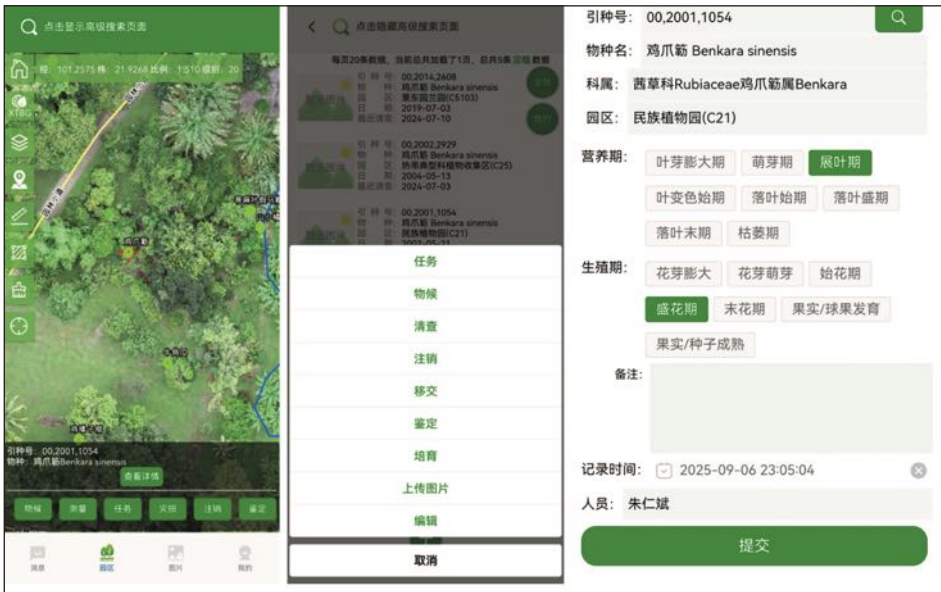

Figure 4: Simplified data entry workflow in XIMS.

### 3. Simplified Operation

Taking into account the practical working conditions of frontline horticultural staff, the new system prioritises extreme simplicity in user interface design and ease of use in daily operations. Users can quickly initiate routine data entry by selecting plants via their precise garden location or through pre-defined task lists. Wherever possible, data input relies on intuitive tap-and-select actions rather than manual text entry, dramatically improving field data collection efficiency. The overarching design philosophy is to make the system feel effortless and supportive—never an added burden—to end users.

### 4. Standardised Information

Data standardisation serves as the foundation of the entire information system. XIMS incorporates several rigorously curated standardised datasets:

A taxonomic nomenclature system compliant with the International Code of Nomenclature for algae, fungi, and plants (ICN), featuring a 30-rank hierarchical classification framework, along with accepted names, synonyms, cultivar names, and over 2 million taxonomic records—including more than 200,000 scientific names linked to Chinese common names.

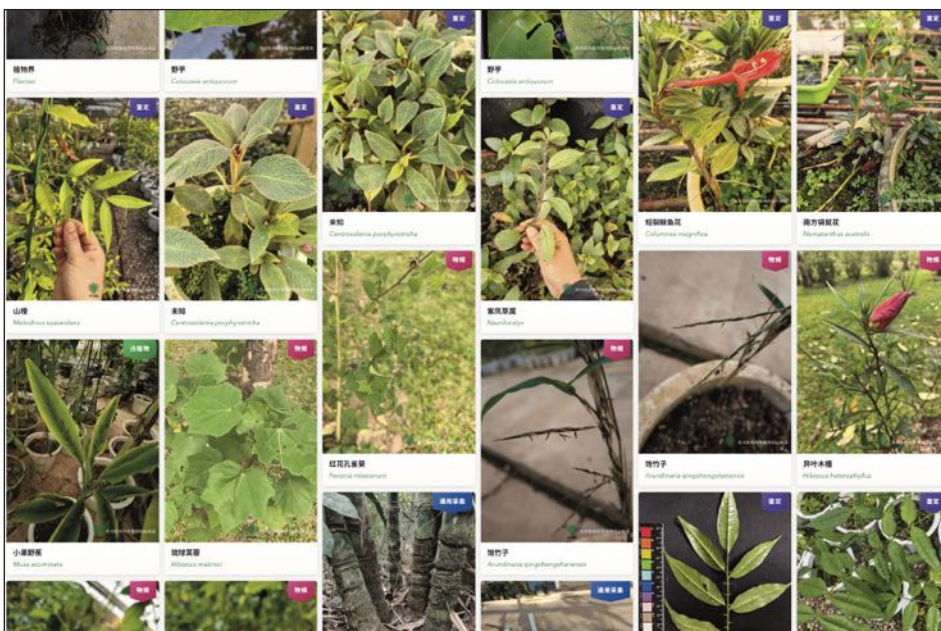

Figure 5: Examples of routine observational records captured through the XIMS.

A geographic coding system based on Baidu Maps, containing over 80,000 city and locality names to ensure consistent and accurate recording of collection and planting locations.

A structured operational data model aligned with the Chinese Botanical Garden Standards System: Definition Standards, Technical Specifications, Performance Evaluation, and Certification Framework (Huang et al., 2019). This model standardises core workflows such as field collection, accession registration, phenological observation, morphometric measurement, and propagation protocols.

Together, these components ensure semantic consistency, interoperability, and long-term usability of botanical data across institutional and international contexts.

### Sticky Code System: The Core Innovation

**The most innovative feature of the new system is the introduction of the “sticky code” concept.**

When a batch of plants is accessioned into the garden, the system automatically generates a single sticky code for that cohort. Every subsequent data record—whether related to the original individuals, their vegetative propagules, or seed-derived offspring—is linked to this same sticky code. Functioning as a digital “plant ID,” the sticky code not only defines the plant’s identity but also chronicles its entire history. Crucially, when taxonomic revisions occur—such as a name update based on new scientific evidence—all records associated with that sticky code are automatically updated across the system, ensuring taxonomic consistency in real time.

Through this mechanism, XTBG has achieved seamless, end-to-end integration of full-lifecycle data for every living accession, establishing a robust data foundation for scientific research, conservation assessment, and evidence-based institutional decision-making.

### Future Outlook

Looking ahead, XTBG plans to further enhance its Plant Information Management System with a focus on the following strategic directions:

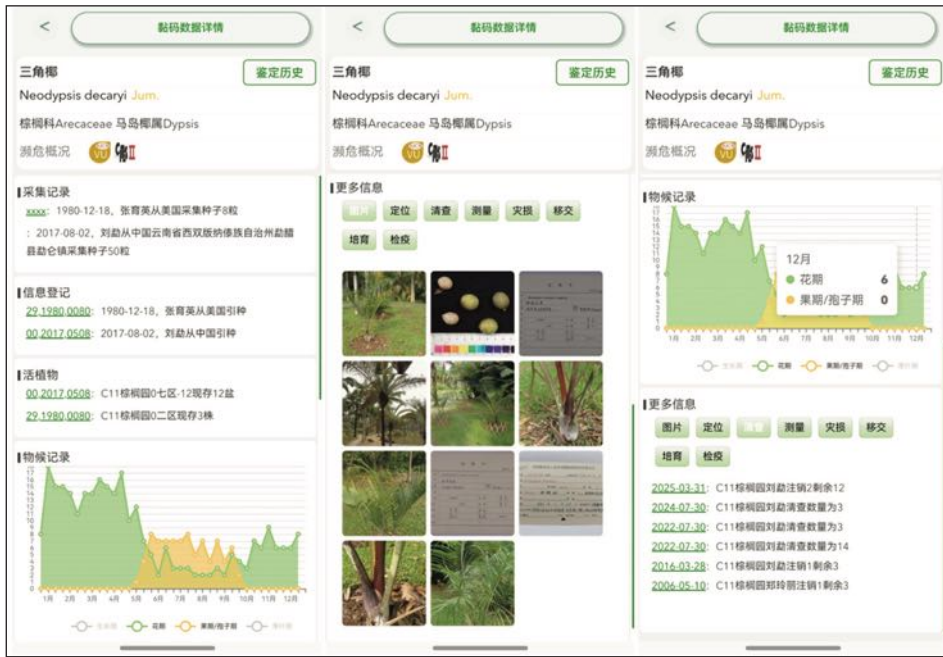

Figure 6: Detailed view of a “sticky code” record in XIMS.



Figure 5: Examples of routine observational records captured through the XIMS.

- **Artificial Intelligence Integration:** Leveraging AI for automated plant image recognition, intelligent diagnosis of pests and diseases, and predictive analytics for plant health.
- **Internet of Things (IoT) Deployment:** Installing environmental sensors across gardens to enable real-time, automated collection of microclimate and soil data.
- **Public Engagement:** Developing interactive public-facing platforms to support citizen science initiatives and enhance science communication and botanical education.

- **Regional Collaboration:** Promoting the establishment of a regional botanic garden data-sharing network to facilitate coordinated conservation efforts and interoperable biodiversity informatics across Southeast Asia and beyond.

### Further reading

- Gao, X.-m., He, S.-a., Gu, Y., & Ling, P.-p. (1996). Computerized management subsystem of living collections information of Nanjing Botanical Garden. *Journal of Plant Resources and Environment*, 5(1), 43–47.

- Ren, H., Jian, S.-g., Zhang, Z., Zheng, X.-c., Zhang, D.-x., Wang, Z.-f., Hao, G., Duan, J., Liao, J.-p., Wei, X.-y., & Fu, D.-z. (2004). Theory and technology of digital botanical gardens: A case from South China Botanical Garden. *Journal of Tropical and Subtropical Botany*, 12(5), 489–494.
- JIAO Yang, SHAO Yunyun, LIAO Jingping, HUANG Hongwen, HU Huabin, ZHANG Quanfa, REN Hai, CHEN Jin. Status and Future Strategies of Chinese Botanical Gardens. *Bulletin of Chinese Academy of Sciences*, 2019, 34(12): 1351-1358
- Gu, J., Ji, D., Wei, Y., Fu, Y., Tao, S., Guo, J., Xie, Z., Huang, M., Hu, Z., & Yan, W. (2024). Design and application of living plant management system at Shanghai Botanical Garden. *Garden*, 41(S1), 26–38.
- Wang, Z. W. (2025). An analysis of the functions of living plant management systems in botanical gardens. *Modern Horticulture*, 48(14), 156–158.
- HUANG Hongwen, LIAO Jingping, ZHANG Zheng. Chinese botanical garden standards system: Definition standards, technical specifications, performance evaluation, and certification framework [M]. Beijing: Science Press, 2019.

Zhu Renbin,  
Information Center of  
Xishuangbanna Tropical Botanical  
Garden, CAS  
zhurenbin@xtbg.ac.cn  
ORCID: 0000-0003-3925-1571

Su Yanping,  
Horticulture and Gardening  
Center of Xishuangbanna Tropical  
Botanical Garden, CAS  
syp@xtbg.org.cn

Cao Zhikun,  
Information Center of  
Xishuangbanna Tropical Botanical  
Garden, CAS  
caozhikun@xtbg.org.cn

# RECONNECTING KEW'S BOTANICAL COLLECTIONS



**Palm House at Kew Gardens.** Home to part of Kew's tropical living collections, widely used for science and conservation. Ensuring clean data and clear links between living plants and their sibling and derived objects in other collections is essential to maintain traceability and support effective research.

Bringing all of Kew's botanical collections into a single shared database is transforming how the organisation manages its data. What were once separate collection objects can now be linked, for example as sibling objects originating from the same collection event or objects derived from one another. This integration improves accuracy and efficiency, strengthens security and compliance, and reduces operational overhead. By reuniting fragmented histories and standardising collections data and processes, Kew is strengthening traceability, enriching curation, and enabling collections data to be shared and accessed beyond the institution for research, conservation, and storytelling.

## Kew's context

Kew's botanical collections span more than 250 years of continuous collecting and today comprise many millions of collection objects, ranging from over six million digitised herbarium specimens to hundreds of thousands of collection objects across the living, seed, DNA, and other collections. For much of their modern history, the botanical collections at Kew were documented in separate database systems,

with more than 60 known systems used at various points across the organisation. Each system reflected the needs, practices, and constraints of individual collections and people. As a result, living plants, herbarium specimens, seeds, DNA samples, and other objects derived from the same field collection event were recorded independently, with few formal mechanisms to express their shared origin. Over time, this scale and fragmentation led to duplication of effort and the gradual divergence and loss of data.

The consequences of separate systems were not merely technical. Inconsistent standards and disconnected records limited staff awareness of related material held elsewhere in the organisation, weakened traceability, and made it harder to use collections strategically for conservation and research. In some cases, the stories behind plants, often useful for public outreach and visitors, were effectively lost even though the material itself remained in cultivation or storage.

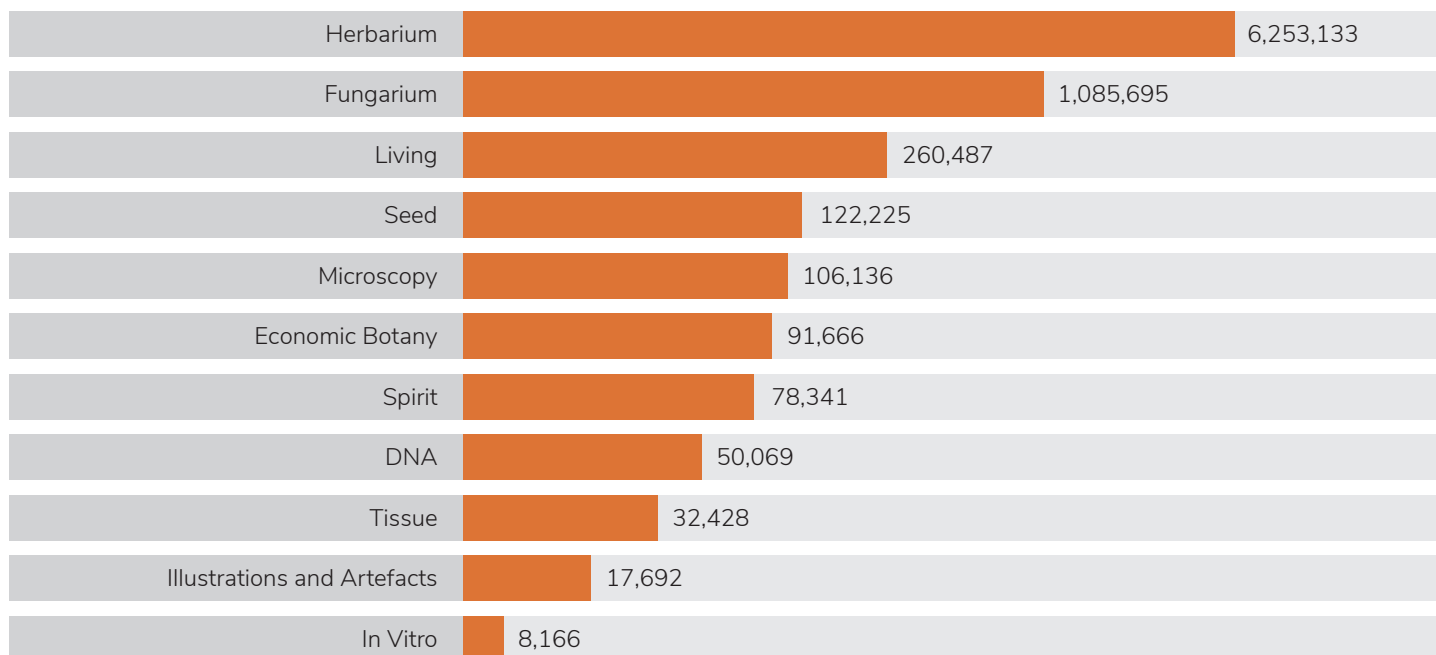

Number of Digitised Object records (log scale)

**Number of digitised collection object records at Kew by collection (January 2026).** Collection sizes range from millions of herbarium records to a few thousand records in smaller collections such as In Vitro, which primarily contains orchid and other seeds that can't be readily grown under standard horticultural conditions.

Addressing this fragmentation became increasingly important as expectations around data quality, compliance, and impact grew. Rather than continuing to manage collections as separate assets, Kew chose to bring them together through a single database system. This work took place over a five-year project completed in 2025, known as the Integrated Collections Management System (ICMS). Running in parallel with the Herbarium digitisation programme, ICMS was part of an overall £30 million investment. This article reflects on the ICMS project, with a particular focus on living collections.

### Living collections play a central role

Among all botanical collections, living collections occupy a unique and pivotal position. They are the only collection that can continuously generate new material for other collections, including seeds and DNA for banking, herbarium vouchers, and an ongoing

*Living collections are the only collection that can continuously generate new material for other collections, while also being the most dynamic and resource-intensive to manage.*

supply of material for research. At the same time, they are the most dynamic and resource-intensive to manage. Plants grow, need watering, die, or are propagated, and each of these changes affect how material is recorded, traced, and used across collections.

Because of this dynamism, high-quality and well-structured records in living collections are not simply desirable: they are essential. Weak and inconsistent data at this stage propagates downstream, affecting the scientific value of herbarium specimens, the reliability of DNA and seed bank holdings, and the interpretability of research and conservation outputs. This is a shared challenge across collections and metacollections. Well-curated living collection records enable more strategic decision-making, such as prioritising taxa for vouchering and banking, identifying material for propagation, and strengthening the representativeness and integrity of associated collections.

The historical context also matters. Living collections at Kew extend back more than 200 years and reflect generations of changing practices, standards, and technologies. By contrast, collections such as the Millennium Seed Bank, established just 25 years ago, were built with robust data requirements, clearer standards, and more modern infrastructure from the outset. Integrating these

very different legacies into a single, coherent system has therefore required not only technical solutions, but careful reconciliation of decades of accumulated inconsistencies.

### From isolated records to linked collection objects

At the heart of this work lies a shift from treating records as standalone entries to understanding them as part of a network of related collection objects. At Kew, a collection object refers to any individual item, e.g. living plant, seed or DNA sample, herbarium or spirit specimen, etc., regardless of which collection it belongs to. In practical terms, this requires a small number of shared concepts to be made explicit.

At Kew, an occurrence represents a single collection event in the wild, where a plant is encountered at a particular place and time. This definition follows Biodiversity Information Standards (TDWG) and Global Biodiversity Information Facility (GBIF) standards. A collection object is essentially any physical item derived from an occurrence that ends up in one of Kew's collections. Objects can be related as siblings when they originate independently from the same occurrence, or through derivation links when one object is produced from another, for example when DNA is extracted from a herbarium voucher.

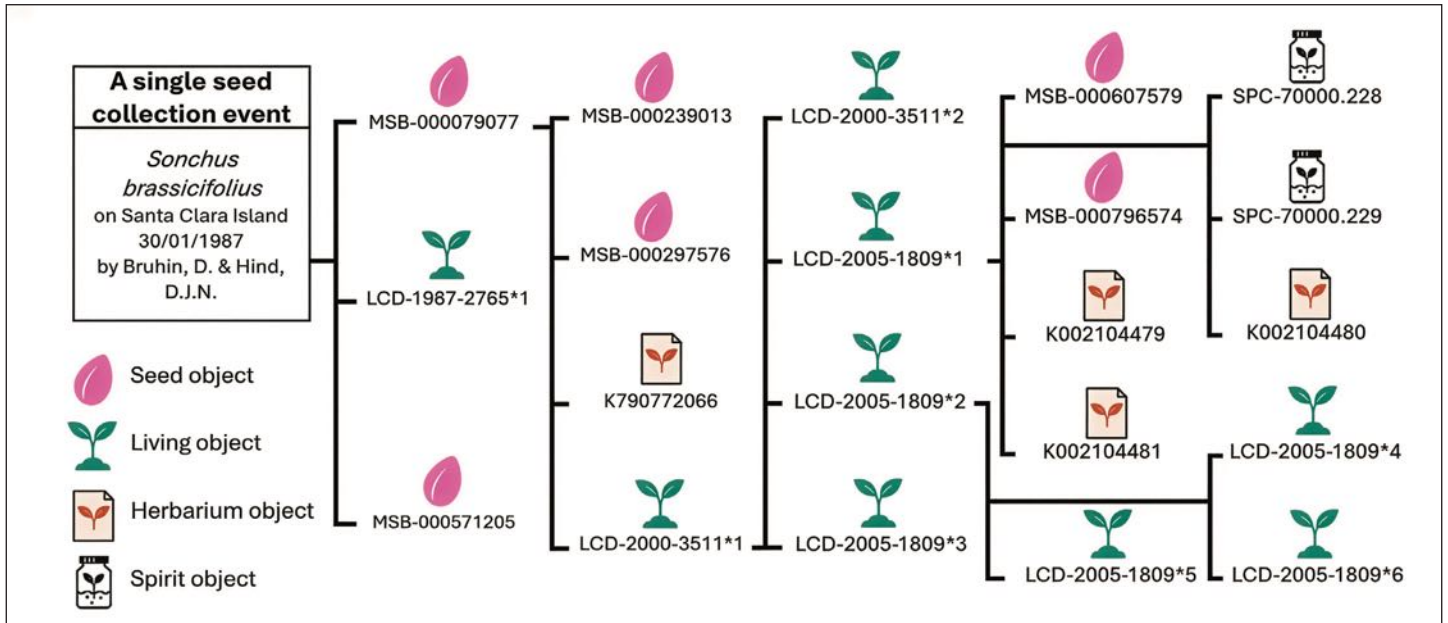

**Seed and living collections are generative in nature.** In this example, a single seed collection event in 1987 gave rise to 21 collection objects across 4 collections over a period of 38 years. Over this time span, changes in data standards and in the definition of an accession have further complicated data cleaning and reconciliation.

Historically, these relationships were inconsistently captured. A single field collection might, over decades, generate not only multiple objects in a single collection but many objects in multiple collections, all recorded separately and sometimes under different names or attributes. Reconstructing these links retrospectively is technically demanding and often requires interpretation, validation, and expert judgement. However, making these relationships explicit transforms isolated records into connected histories, restoring context and meaning that would otherwise remain hidden.

## ICMS and the technical and cultural change

The adoption of an Integrated Collections Management System (ICMS) has been critical to modernise the collections. Technically, it provides a shared infrastructure and data model that allows all collections to be managed within a single system, using common fields and relationship types. Conceptually, it reframes collections as interdependent components of a wider whole, rather than as silos.

Equally important has been the cultural shift accompanying this change. Standardising fields and processes across collections functions as a form of contract: an agreement that information will be recorded in ways that are meaningful and reusable beyond any single team. Achieving this has required close collaboration between Kew's collections, who

bring essential and specialised curatorial knowledge, and data and systems teams, who design and implement the underlying structures.

While this process has involved significant challenges, it has also generated positive outcomes. Shared problem-solving and iterative testing have fostered new, organic collaborations between horticulture, science, and the data teams. In many cases, the act of linking records has itself revealed gaps, inconsistencies, and opportunities that would not have been visible within isolated datasets.

## What linking records unlocks

As links between collection objects get reconstructed, their practical value becomes apparent. For living collections, this means being able to see, often for the first time, how material in cultivation relates to seed accessions, herbarium vouchers, or DNA samples held elsewhere in the organisation. This visibility supports more informed and strategic decisions.

For example, reuniting an extant living tree with its long-lost wild herbarium voucher can substantially increase confidence in its taxonomic determination, while simultaneously enhancing the scientific value of both objects. Similarly, identifying living accessions that lack associated herbarium vouchers can guide targeted vouchers to strengthen taxonomic

certainty and future research value. In a dynamic collection where space, staff time, and infrastructure are finite, these connections allow effort to be directed where it has the greatest collective impact.

Linking also reduces duplication. Where multiple records previously referred, often unknowingly, to the same original collection event, consolidation around shared occurrences improves data completeness while simplifying workflows. This has implications for compliance and reporting, but also for research and storytelling, where traceability and context are increasingly expected. At scale, the challenge still remains; tens of thousands of potential links, particularly between living and herbarium material, still need to be reconstructed and validated. Nonetheless, even partial linking has already begun to unlock value.

An important outcome of this work is that Kew's collections data are now easier to share and reuse beyond the institution. By structuring records consistently and making relationships explicit, ICMS supports publication through international infrastructures such as GBIF, BGCI's PlantSearch, as well as access via Kew's own Kew Data Portal. This improves transparency, discoverability, and interoperability, allowing Kew's collections to contribute more effectively to global research and conservation efforts.

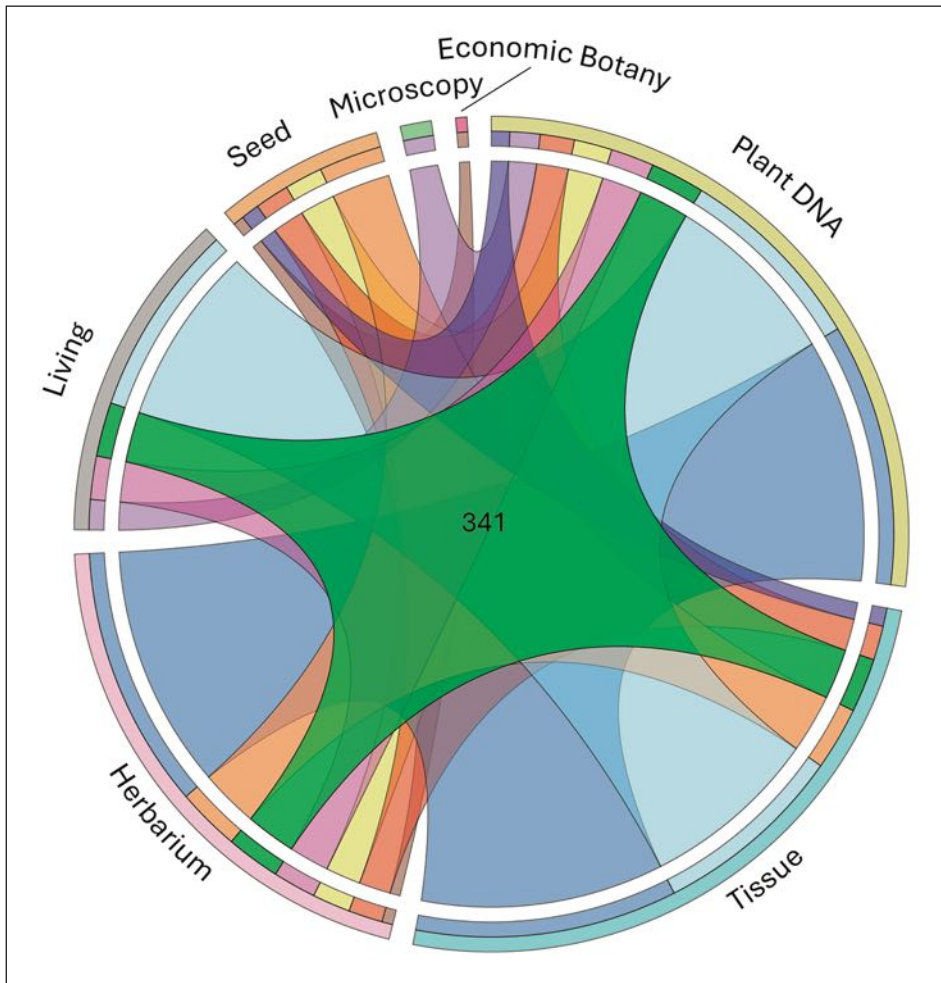

**Links between collection objects spanning three or more collections at Kew ( $\geq 50$  links).** Visualising these connections reveals patterns of interaction and use, helping to inform curation, research, and conservation. The highlighted green area shows current links between the Herbarium, Living, Tissue, and DNA collections (341 links), while underscoring the scale of historical links that remain to be cleaned and reconstructed.

### An unfinished but ongoing process

Now that ICMS is in place, the work of linking records is far from complete. Many historical records require additional cleaning, harmonisation, and expert review; and not all relationships can be resolved with certainty. Incremental improvements, linking where confidence is high and flagging uncertainty where it remains, are already improving data consistency and guiding further development. For example, based on current assessments, we estimate that at least 60,000 links will be created between the living and herbarium collections, around 10,000 between living and seed collections, and approximately 7,000 between living and DNA collections.

Initial steps in the linking process focus on exact matching and rule-based approaches, using shared identifiers, locality information,

collection dates, and collector details to establish high-confidence links. These methods provide a robust foundation for linking large volumes of records efficiently while minimising the risk of false associations.

More complex cases require probabilistic approaches that draw on combinations of partially matching fields, such as variant collector names and field numbers, locality names or rounded coordinates. In these instances, automated methods are complemented by curatorial judgement, particularly where legacy practices or incomplete documentation introduce ambiguity. The combination of systematic methods and expert review is essential for addressing edge cases while maintaining confidence in the resulting links.

Record cleaning and linking is a slow, ongoing process at Kew, shaped in part by the scale and historical depth of the collections, as well

as by staff capacity. As a result, improvements are introduced incrementally within ICMS. This approach avoids disruption to day-to-day collection management and allows the system and its data to evolve alongside regular operational work.

### Reflections

Kew's experience highlights that reconnecting collections is as much a cultural shift as it is a technological one. Moving from isolated records to linked ones transforms collections from internally managed assets into resources that can be more easily discovered, accessed, and used by the wider research and conservation community. Achieving this requires shared standards, shared responsibility, and a willingness to design systems that serve the whole organisation and its users.

For living collections in particular, the benefits are amplified. As the most dynamic and generative collection, they sit at the centre of a web of relationships that underpin conservation, research, and public engagement. Making these relationships visible not only improves internal decision-making, but also increases the availability, relevance, and long-term resilience of collections for external users.

Looking ahead, there is clear potential to extend this approach beyond institutional boundaries. A broader ecosystem of shared standards and processes would enable collections across the world to connect more effectively, amplifying collective impact. While the work at Kew is ongoing, it demonstrates how integrating systems, data models, and people can transform fragmented histories into connected resources, and in doing so, unlock new opportunities for research and outreach.

**Arnau Ribera Tort,**  
Living Collection Support Officer,  
[a.ribera\\_tort@kew.org](mailto:a.ribera_tort@kew.org)

**Thomas Freeth,** Head of Living  
Collection Support,  
[t.freeth@kew.org](mailto:t.freeth@kew.org)

**Robert Turner,**  
Digital Operations Team Lead,  
[r.turner@kew.org](mailto:r.turner@kew.org)

**Royal Botanic Gardens,**  
Kew, TW9 3AE, Richmond,  
United Kingdom

# ANALYSIS OF THE FUNCTIONS OF THE SHANGHAI CHENSHAN BOTANICAL GARDEN LIVING PLANT MANAGEMENT SYSTEM

Botanic gardens aim to collect and conserve plants while providing the public with places for recreation and appreciation. Faced with rich plant species and cultivars, a complete living plant management system is required to collect and manage this information. Based on the practical operations of living plant management at Shanghai Chenshan Botanical Garden, this paper presents the related functions and requirements of the living plant management system. It explores a management model based on a web-based management system platform and mobile applications. Combined with the information collection management module currently under development, a comprehensive system suitable for living plant management in various botanic gardens has been formed, providing a case reference for living plant management in major botanic gardens.

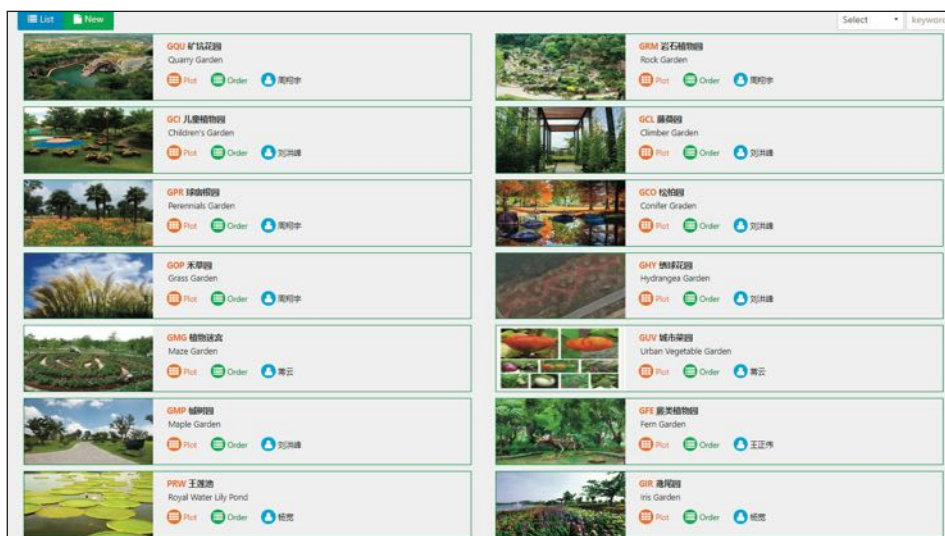

Figure 1: Specialised garden management interface at the Living Plant Management System.

Botanic gardens are important bases for the conservation of national strategic plant resources, undertaking tasks such as plant diversity conservation and sustainable use, reintroduction, science popularisation and consultation, and scientific research. In 2000, Botanic Gardens Conservation International defined a botanic garden as: 'An institution having a documented collection of

living plants and maintaining them for the purposes of scientific research, conservation, exhibition, and education'. Therefore, plant records are one of the key elements constituting a botanic garden and are the foundation for realising its five major functions: Conservation, scientific research, education, recreation, and development (Shan'an, et al. 2005). Plant records increase the value and importance of

plant collections; if records are lacking, the collected species lose or diminish in scientific value (Shubo, 2016). Thus, the information archive is the soul of a botanic garden's living plants (Leadlay, 2005). A living plant information management system helps in the effective, convenient management, retrieval, and utilisation of plant resource archives. Simultaneously, the level of informatisation in living plant management reflects a botanic garden's management capability and research strength. From the construction and management of specialised gardens to the standardised recording of plant information (Shubo, 2016), a management system platform that is both easy to manage and convenient for querying and downloading is needed. Based on extensive research on domestic and international living plant management technologies and solutions, through independent research and development and close integration with daily living plant management operations, a complete set of living plant business management software and solutions has been developed. This provides comprehensive support for the management, scientific research, science education, and management decision-making of a botanic garden's living plant resources.

RegSN	ChineseName	LatinName	Collector	CollectSN	LivingCount	Traits	PlantType	CollectPlace	Provider	CollectYear	Month	Day	ChineseFamily	Family	ChineseGenus	Genus
20120241	鲁弗尔齿叶灰毛菊	Haplocarpha rueppelii	田旗	WS0240	0	保育	草本		肯尼亚	2012	1	23	菊科	Asteraceae	齿叶灰毛菊属	Haplocarpha
20120227	斑叶芦荟	Aloe lateritia	田旗	WS0226	2	多肉	灌木		肯尼亚	2012	1	23	阿福花科	Asphodelaceae	芦荟属	Aloe
20120229	芦荟属	Aloe sp.	田旗	WS0228	0	多肉	灌木		肯尼亚	2012	1	23	阿福花科	Asphodelaceae	芦荟属	Aloe
20120233	林密铁角蕨	Asplenium linkii	田旗	WS0232	0	保育	草本		肯尼亚	2012	1	23	铁角蕨科	Aspleniaceae	铁角蕨属	Asplenium
20120237	圆叶白粉藤	Cissus rotundifolia	田旗	WS0236	0	保育	藤本		肯尼亚	2012	1	23	葡萄科	Vitaceae	白粉藤属	Cissus
20120232	圆叶白粉藤	Cissus rotundifolia	田旗	WS0231	0	保育	藤本		肯尼亚	2012	1	23	葡萄科	Vitaceae	白粉藤属	Cissus
20120223	圆叶白粉藤	Cissus rotundifolia	田旗	WS0222	0	保育	藤本		肯尼亚	2012	1	23	葡萄科	Vitaceae	白粉藤属	Cissus
20120230	景天科	Crassulaceae sp.	田旗	WS0229	0	多肉	草本		肯尼亚	2012	1	23	景天科	Crassulaceae		Crassulaceae
20120226	景天科	Crassulaceae sp.	田旗	WS0225	0	多肉	草本		肯尼亚	2012	1	23	景天科	Crassulaceae		Crassulaceae
20120231	景天科	Crassulaceae cv.	田旗	WS0230	0	多肉	草本		肯尼亚	2012	1	23	景天科	Crassulaceae		Crassulaceae
20120235	基布葡萄茎	Cyphostemma kibweziense	田旗	WS0234	1	保育	灌木		肯尼亚	2012	1	23	葡萄科	Vitaceae	葡萄茎属	Cyphostemma
20120239	高坡鳶尾	Dietes iridioides	田旗	WS0238	0	保育	草本		肯尼亚	2012	1	23	鳶尾科	Iridaceae	高坡鳶尾属	Dietes
20120224	大戟属	Euphorbia sp.	田旗	WS0223	0	多肉	灌木		肯尼亚	2012	1	23	大戟科	Euphorbiaceae	大戟属	Euphorbia
20120225	伽蓝菜属	Kalanchoe sp.	田旗	WS0224	0	多肉	草本		肯尼亚	2012	1	23	景天科	Crassulaceae	伽蓝菜属	Kalanchoe
20120228	岩生仙人掌	Kleinia petraea	田旗	WS0227	1	多肉	草本		肯尼亚	2012	1	23	菊科	Asteraceae	仙人掌属	Kleinia
20120238	滑囊蕨火炬花	Kniphofia thomsonii	田旗	WS0237	0	多肉	草本		肯尼亚	2012	1	23	阿福花科	Asphodelaceae	火炬蕨属	Kniphofia
20120234	石蒜	Lycoris radiata	田旗	WS0233	0	保育	草本		肯尼亚	2012	1	23	石蒜科	Amaryllidaceae	石蒜属	Lycoris
20120240	花叶车前	Plantago cv.	田旗	WS0239	0	园艺	草本		肯尼亚	2012	1	23	车前科	Plantaginaceae	车前属	Plantago

Figure.2: Introduction information management interface at the Living Plant Management System.

The living plant management work at Shanghai Chenshan Botanical Garden began in 2012. The web-based Living Plant Management platform was developed in 2017, the 'Gardener's Notes' app in 2018, and the WeChat mini-programme application in 2020. By 2025, the 'Gardener's Notes' app was optimised, and its functions were integrated into the WeChat mini-programme, truly completing the construction of the living plant management information system and forming a complete set of living plant management solutions.

### Living Plant Management System Web Platform – The Online Platform for Comprehensive Plant Information Management

The Living Plant Management Web Platform is designed based on botanic garden management standards and key business processes. After analysing and optimising previous botanic garden management business processes, the platform's main business processes are determined to include: collection and introduction, in-garden planting, registration application, plant registration, label application, label management, labeling and positioning, and observation records. The data accumulated through the system's business processes are ultimately used to generate applications such as living plant reports, specialised garden management, field inventory, and species catalogs (Qiuling et al., 2017). Based on the primary management needs of the botanic garden, the

PlantSN	Event Category	Event Content	Manager	ManageTime
20180349-1	修剪	人为	林琛	2018-12-06T13:43:36
20171526-7	死亡	人为	林琛	2018-12-18T15:33:04
20072091-14	死亡	人为	龚利霞	2019-01-10T10:52:29
20070543-2	药品	喷洒药品	龚利霞	2019-01-16T17:05:24
20100558-14	修剪	人为	吴治雄	2019-03-01T13:45:06
20161345-5	修剪	人为	吴治雄	2019-03-01T13:43:17
20123208-6	修剪	人为	吴治雄	2019-03-01T13:53:46
20123208-8	修剪	人为	吴治雄	2019-03-01T13:56:25
20171285-13	其他管理	人为	吴治雄	2019-03-01T15:10:31
20100558-15	其他管理	人为	吴治雄	2019-03-01T15:12:05
20161331-5	其他管理	人为	吴治雄	2019-03-01T15:13:06
20100206-2	其他管理	人为	吴治雄	2019-03-01T15:15:59
20123208-10	其他管理	人为	吴治雄	2019-03-01T15:22:53
20060539-1	病虫害	人为	梅迪	2019-03-13T09:46:58
20060486-1	病虫害	人为	梅迪	2019-03-13T09:38:10
20072648-27	其他管理	人为	吴治雄	2019-03-15T15:11:25
20102615-4	其他管理	人为	吴治雄	2019-03-15T15:50:33
20171289-6	其他管理	人为	吴治雄	2019-03-15T15:17:00
20102615-6	其他管理	人为	吴治雄	2019-03-15T15:57:25
20102615-5	其他管理	人为	吴治雄	2019-03-15T16:11:30

Figure 3: Plant maintenance management interface at the Living Plant Management System.

Web platform has established three information management pathways.

The first is the specialised garden management pathway, structured around the information and the person in charge of a particular area of the garden. Platform managers create and modify specialised gardens and their name codes based on the development needs of the botanic garden. Next, they assign the person(s) in charge for the specialised gardens; finally, the responsible person(s) oversee the division of plots (as shown in Fig.1).

The second pathway is the introduction information management pathway, structured around the batch-upload of individual plant records. When species are entered into the system in the same batch, a work batch is

automatically generated; all species in the same batch can be queried; each species is automatically assigned a registration number, and individual plant numbers are automatically generated based on the number of the species (as shown in Fig.2).

The third pathway is the plant maintenance management pathway, structured around the maintenance management module. The platform provides for those responsible person(s) of specialised gardens a space to record management events such as pruning and fertilising for individual plants, record their phenology and changes in planting location at different times, and upload the management events, phenological records, and planting location information to the Web platform (as shown in Fig.3).

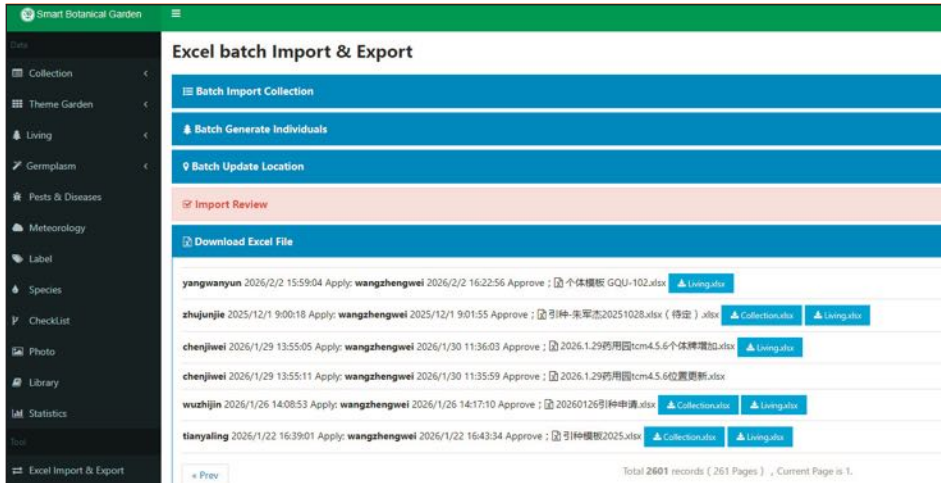

Figure 4: Batch data import and export interface at the Living Plant Management System.

These three information lines are interconnected through the point of the plant individual, forming a complete information loop. The main features and functions of this platform are detailed below.

## 1.1 Data Import Standardisation

### 1.1.1 Plant Management Information Standardisation

As shown in Figure 4, to prevent data errors caused by manual input, the Web platform database supports batch data import/export processing workflows. According to the purpose of data import, users can select templates provided by the management system, such as the introduction information template, new plant individual template, plant planting location change template, and display label application template. By filling in the required content according to the corresponding template specifications, data can be formally imported. Simultaneously, data tables within the database, such as the introduction registration number table, plant individual table, and death table, support data download and export, enabling users to obtain real-time updated data.

### 1.1.2 Planting Positioning Management Standardisation

Planting positioning management adopts a regional plot-based management approach. The garden area is divided into regions by function, such as specialised gardens, landscape areas, mountain areas, and introduction nurseries. These are further divided into plots based on roads, rivers, bridges, pergolas, etc. Plots are represented by a region code plus a plot number, e.g., Cherry Garden code is GCH, plots are GCH-

1, GCH-2, etc. By filling in the planting location in the introduction information template, after import, species data can be automatically aggregated into plot and specialised garden data. Data such as species lists, individual plant counts, and counts of introduction registration numbers for plots or specialised gardens can be downloaded in real-time to generate species and individual tables. Changes in plant planting locations only require filling in a new plot code to complete the update, achieving real-time data updating, downloading, and display.

### 1.1.3 Taxonomic System Family/Genus Standardisation

The Living Plant Management System adopts the APG IV classification system. When importing the introduction template, there is no need to fill in family and genus scientific names. The system automatically supplements the family and genus scientific names and Chinese names based on the genus name within the species scientific name in the template. The species tree in the Living Plant Management System is generated in real-time based on the APG IV classification system and the living plant database data, and plant scientific name information is linked to the leaf nodes of the classification tree.

## 1.2 Data Verification Automation

### 1.2.1 Species Scientific Name Verification Automation

Based on the plant scientific name species database within the system, automated verification, matching, and filling of species scientific name information is performed after data import. The Web platform species

database integrates the Flora of China, World Flora Online(WFO), Plants of the World Online (POWO) and cultivar data from the Royal Horticultural Society (RHS) of the UK, totaling over 1,442,000 plant scientific names (include synonyms names) and 300,000 cultivar names. Therefore, after introduction information enters the database, the background compares the species scientific name with names in the species database. Unmatched names are displayed in the review section for administrator verification. After processing the data in the review section, unmatched species scientific name information is added to the species database for direct verification in the future. The automation of species scientific name verification increases the accuracy and consistency of imported scientific names and reduces the workload of data managers.

### 1.2.2 Registration Number and Individual Number Generation Automation

After data verification and import into the management system Web platform, the system automatically generates registration numbers and individual numbers. Information for individual number labels can be automatically retrieved from the system. The individual label table can be directly used with a label printer to create individual label stickers. Logged-in users can scan to record phenological observations, growth status, management events, etc., for plant individuals, and can also take photos and upload them to the system. Non-logged-in users can scan to browse popular science introductions of plants.

## 2 Mobile Mini-Programme 'Gardener's Notes' Module – Daily Plant Maintenance and Monitoring

As shown in Figure 2, the mobile mini-programme 'Gardener's Notes' function can record various data of living plants, covering dimensions such as living plant species, planting location, phenology, maintenance, growth status, pests and diseases, and phenotypic traits, in forms including text, audio, pictures, and video. Scanning the QR code on a living plant individual label can quickly retrieve the latest data for that plant from the Living Plant Management Web platform, update living plant data on-site instantly, and synchronise it immediately to the Web platform. The main features and functions are detailed below:

## 2.1 Real-time Data Update

This mainly involves daily management and maintenance work, such as phenology records, location information, and maintenance events. During maintenance, if a phenology record needs to be updated, simply scanning the QR code on a living plant individual label will display the time, content, and recorder of the last phenology record, effectively avoiding duplicate recording. Location information can be displayed with latitude and longitude via Baidu Maps by clicking the phone's location function. Maintenance events can record tasks like watering, fertilising, spraying, and pruning during the maintenance process. During phenology recording, maintenance management, and location marking, users can take or import videos, photos, and audio recordings, which can be viewed by browsing in the gallery.

## 2.2 Convenient Data Statistics and Querying

During garden maintenance, when needing to query species introduction archives, species information, specialised garden plant lists, phenology records, statistical reports, etc., scanning the code provides comprehensive and up-to-date data about the living plant. Species scientific names are linked to the Flora of China; clicking on them allows viewing species information.

## 3 Mobile Mini-Programme 'Plant Share' – Plant Material Collection Application and Review

The Living Plant Management System mini-programme, released on the WeChat platform, can expand connections between the international public, researchers, and the botanic garden's living plants. It provides a window for public science education and external services, meeting the public's needs to query introduced and cultivated plants in the botanic garden and researchers' needs for sampling scientific research materials. The main functions are as follows:

### 3.1 Online Species Query

Registered/logged-in visitors can query based on different needs using Latin names, Chinese names, genus names, or family names. Based on the current types and cultivars of living plants in the database, after searching, the system automatically counts

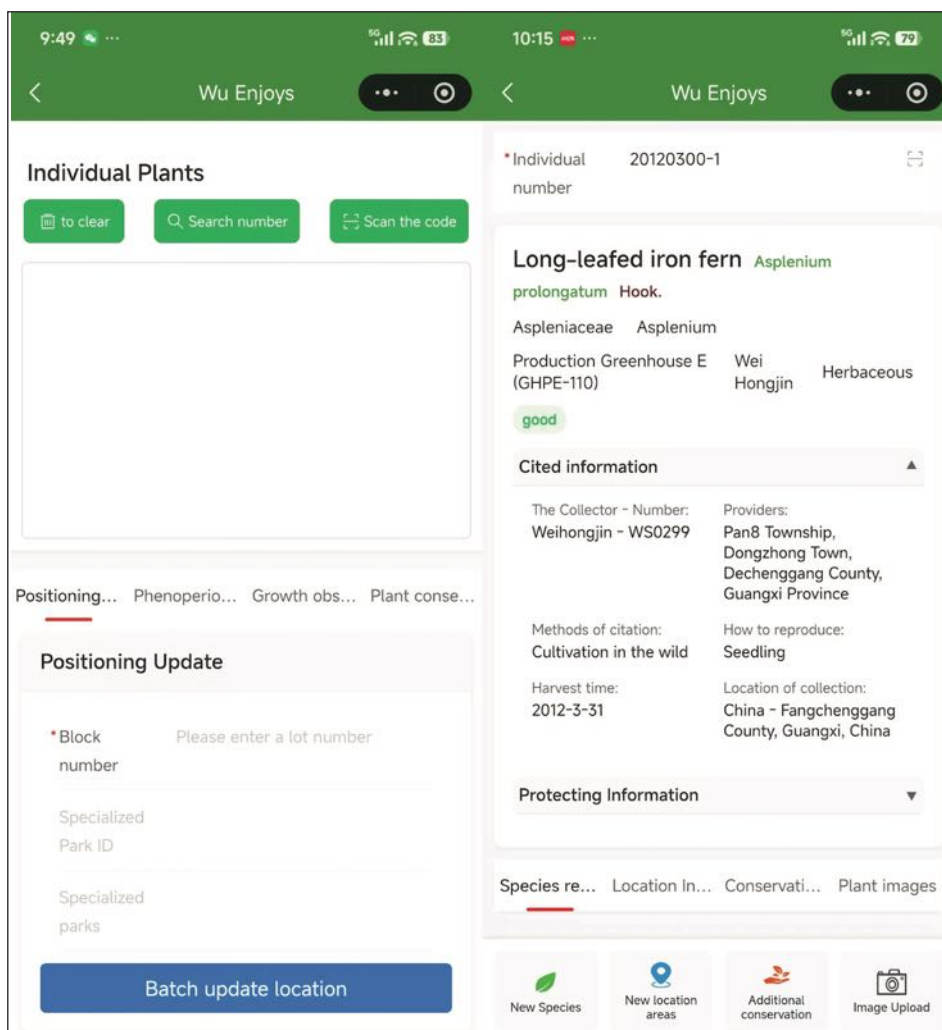

Figure 5: Various data recording interface for living plants at Gardener's Notes.

species and family/genus information. Species and cultivars are presented in lists for quick dropdown browsing.

### 3.2 Online Plant Material Application and Approval

As shown in Figure 3, For researchers needing to apply for plant materials, after registering and logging in, they can apply online for botanic garden living plant material collection. After filling in basic applicant information and querying the required plant material, applicants can directly add species to the collection list and mark the requirements for species on the list. Currently, the mini-programme allows marking options such as living plant, seeds, roots, stems, leaves, flowers, and fruits for applicants to choose from, while the corresponding required material quantities also need to be filled in. After finalising the collection list, the application can be submitted, and the application form enters the online review and circulation approval process. Living plant managers review the

received electronic collection application, fill in the departmental liaison person for collection coordination, and can conduct the review, providing timely feedback of the review results to the applicant. After the responsible leader approves, the system sends an SMS to remind the collector to bring the institutional letter of introduction and the collection application form and come to the garden for collection on the date specified in the application. The department staff responsible for receiving the applicant manually inputs or scans the individual numbers of the collected plants at the collection site. After the collection is fully completed, the letter of introduction and collection application form are submitted to the Living Plant Information Management Group, and 'Collection Completed' is clicked within the mini-programme, at which point the entire collection process ends. For the above online application and approval process, when the applicant submits the application, the plant collection application form and collection list are instantly synchronised to the management system.

## 4 Function Module Under Development- Field Collection Voucher

The currently developed and used entire Living Plant Management System is based on introduced and collected plants entering the botanic garden and their introduction information (as shown in Figure 7), being entered into the management system. However, as part of introduction and conservation work, the more important content is the management of field collection voucher for introduced plants (as shown in Figure 8), which lays the foundation for the final plant reintroduction work. From the botanic garden's perspective, it needs to cultivate, maintain, and propagate plants well, to research the mechanisms of plant endangerment, and apply this to the final stage of plant reintroduction. All of which rely on detailed field original habitat information, including habitat, associated species, pests and diseases, etc. Only by managing field collection information well can the botanic garden's ex situ conservation work ultimately be implemented. The main features of the field collection information management module are as follows:

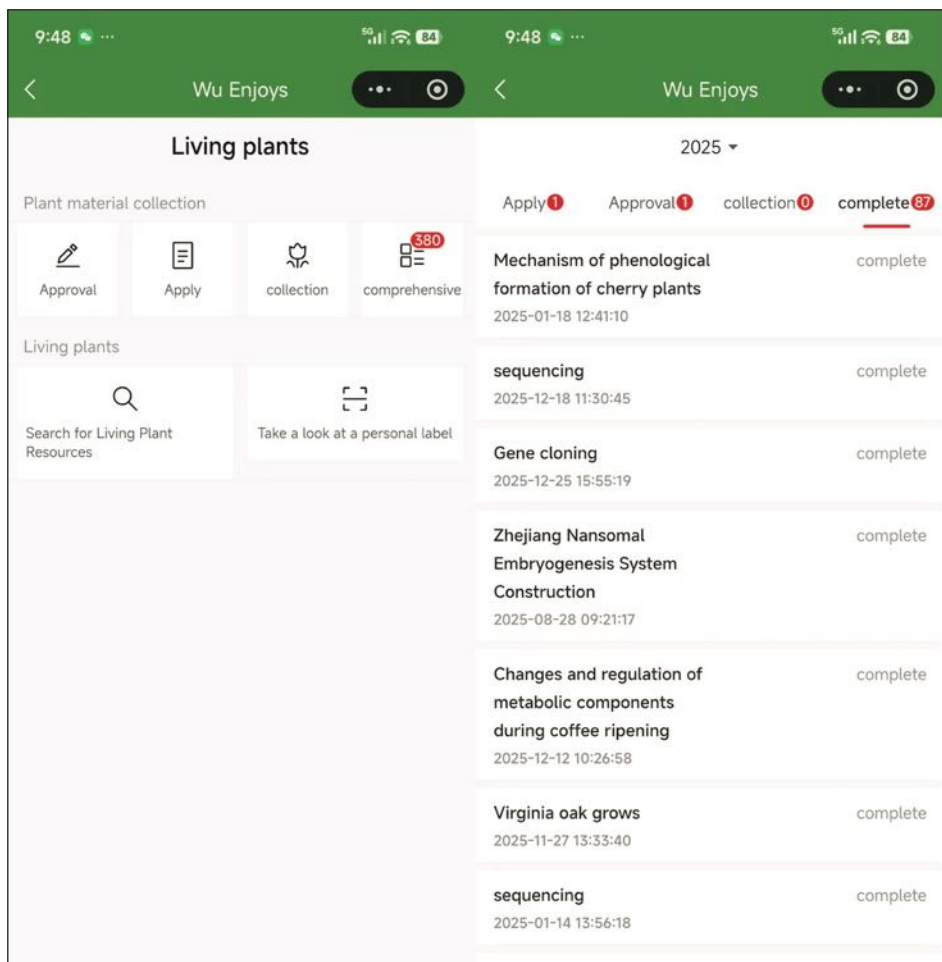

Figure 6: Interface for searching living plant resources and applying for plant material collection at Gardener's Notes.

Collection Information				
SN Information				
RegSN	20192230	ShipmentSN	weihongjin20191103	
Basic Information				
Collector	韦宏金	CollectSN	JSL7465	
CollectWay	野外引种	Provider		
CollectCount	1	CollectDate	2019 11月 3日	
Traits	蕨类	PlantType	PlantType	
Specification		Conservator		
Remark	蕨类草本苗			
Species Information				
LatinName	Polystichum liui			
ChineseName	正字耳蕨			
Number	Ching			
ChineseSynonym		LatinSynonym		
ChineseFamily	鳞毛蕨科	Family	Dryopteridaceae	
ChineseGenus	耳蕨属	Genus	Polystichum	
RareEndangered				
Geographic Information				
Country	China - 中国	Longitude	28°14'6.68"北	
Province	贵州	Latitude	107°05'1.45"东	
Place	遵义市绥阳县黄泥水国家级自然保护区元生坝保护站(九龙村)		Altitude	726

Figure 7: Specific Introduction Information of Individual Plant interface at the Living Plant Management System.

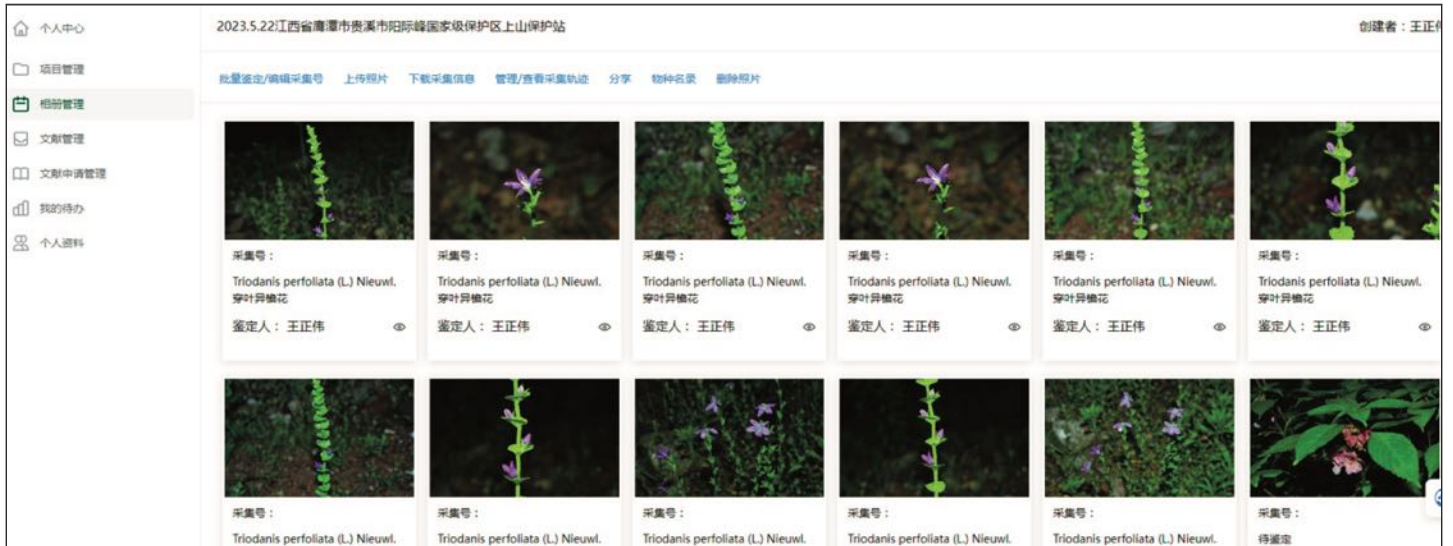

Figure 8: Current interface of the collection information management module.

#### 4.1 Voucher Photograph Management

During field introduction and collection, a large number of photographs of the site habitat, whole plants, and plant parts are taken. These need to be uploaded to the database along with identification information. Editing work is also required for photographs, involving entering information such as the collection number of the collected species, flowering/fruitletting period, and plant parts, facilitating later querying or filtering of field photographs based on objectives.

#### 4.2 Collection Track Management

During field introduction and collection, especially when targeting specific species, it is often necessary to locate the coordinates of the current plant. The route of the field investigation also needs to be recorded to facilitate later field distribution surveys for specific species. Recording field routes facilitates later large-scale baseline surveys or gap-filling surveys within a region. By aggregating all field collection routes, regional collection research hotspots, and areas of collection/research blind spots can be identified, aiding future introduction and conservation work.

#### 4.3 Collection Information Management

After field work concludes, organising collection information is also a huge task, requiring species identification based on photographs, specimens, etc., and supplementing detailed collection information such as collector, collection location, collection time, and associated species. The collection information management function is based on the previous two

points, generated directly by the database. Through photographs and tracks, latitude, longitude, and altitude information can be directly extracted. Based on these, collection location information such as province, city, county, and township can be inversely supplemented, and the collection date can also be extracted. The collection number supplemented in photograph management can also be directly linked to the collection record. Based on a unified template, the collection information table can be directly exported, greatly reducing the workload of information organisation.

The field collection information management module can record all field information of ex situ conservation species in detail, facilitating later information traceability. Combined with the current botanic garden living plant management system, which records from plant entry registration to the final death record of plants, this entire management system is the most comprehensive and complete.

Shanghai Chenshan Botanical Garden has always been committed to ex situ conservation work in East China, continuously experimenting with new technologies and methods, and innovating through the development of the Living Plant Management System. We have gained a relatively comprehensive understanding of the processes for managing living plants. Through the development and exploration of the mobile mini-programmes 'Gardener's Notes' and 'Plant Share' used in conjunction with the Living Plant Management System Web Platform, we have conducted beneficial exploration into the application of new technologies in living plant management.

The development of field collection information organisation functions also provides a case reference for the future application of new technologies in living plant management. Only by continuously combining new technologies and methods with living plant management can botanic garden living plant resource management, scientific research, science education, and management decision-making become more intelligent and efficient.

#### References

- Shan'an, H. Zuoshuang, Z., Yin, G., et al. Botanic Garden Science[M]. Beijing: China Agriculture Press, 2005.
- Shubo, H. 2016. Enlightenment of American Park Plant Information Management for Chinese Botanical Gardens[J]. Modern Landscape Architecture, 2016, 13(07): 573-578.
- Leadlay, E. Darwin's Garden Technology Handbook[M]. Henan Science and Technology Press, 2005.
- Qiuling, W., Chen Bin, C., Wang Wenquan, W., et al. Design and Implementation of an Ex Situ Conservation Information Management System for Chinese Medicinal Plant Germplasm Resources[J]. Modern Chinese Medicine, 2017, 19(09): 1207-1210+1232.

Wang Zhengwei and Zhou Wei  
Shanghai Chenshan Botanical  
Garden Urban Horticulture  
Technology R&D and  
Promotion Center,  
Songjiang, Shanghai 201602



# AN UPDATED LIVING COLLECTIONS POLICY AT THE GENEVA BOTANIC GARDEN

## Introduction

A living collections management policy is an essential tool that defines the strategic direction for the development of a botanic garden. It not only identifies strengths but also highlights weaknesses, helping to streamline efforts and establish priorities. More than just an inventory, this policy provides a qualitative analysis of the living botanical heritage we manage and for which we have a responsibility to conserve and enhance.

With a fully certified organic garden, a herbarium containing over 6 million specimens, a library with 120,000 volumes, and many ongoing research projects in Switzerland and abroad, the Botanic Garden of Geneva ranks among the world's leading botanical institutions. The garden itself covers 28 hectares across three sites. A team of around 40 permanent staff members, including 32 gardeners (26 full-time equivalents), manages over 11,000 different taxa (species, subspecies, varieties, and cultivars) in the living collections.

Our new living collections management policy, which outlines objectives for the period 2024-2034, follows an initial assessment conducted in 2017. The main goals are to select and document our living collections, group them into categories, evaluate them based on established criteria, and ultimately define objectives for their development. The results show that priority collections are almost always those where there is a strong connection between a researcher and the gardener in charge. We plan to reassess our living collections in eight years to determine whether the objectives set have been met and to decide on the future development of our botanical heritage.

## 40 living collections

Botanic Gardens Conservation International (BGCI) defines a living collection as a group of cultivated plants assembled for a specific purpose, which may be geographic, taxonomic, thematic, or ecological based on their sys-

tematic classification, geographic distribution, habitat, or function (Gratzfeld, 2016). Based on this definition and the garden's overall botanical heritage, 40 collections have been identified, inventoried and documented in our management database: Botalista software (<https://botalista.community/>).

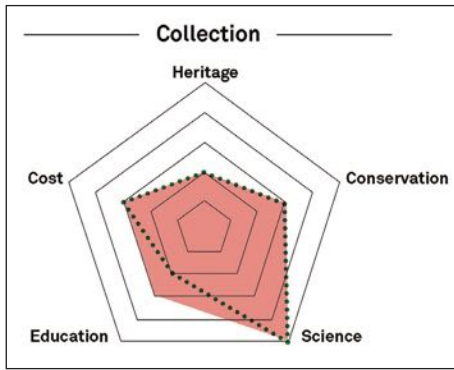

Example of a pentagonal evaluation diagram for a collection of the Geneva Botanic Garden with comparison between evaluation in 2017 (green dots) and 2023 (pink). This fictitious collection would have a high scientific significance (5/5), an average conservation significance (3/5), an average cost (3/5), an average educational significance (3/5), higher than it was in 2017 (2/5), and a rather low heritage value (2/5).

Each collection has been summarised in a description profile together with an exhaustive list of all the cultivated plants it contains. This profile defines the collection, locates it within the garden, summarises its history, and lists the acquisition methods of the plant material. Additional data is also provided: the number of taxa and cultivated specimens (indicating the proportion of duplicates found in the collection per taxon); the proportion of horticultural varieties versus wild taxa; the representativeness (indicating the percentage of taxa in each collection compared to the number of taxa described at the global level).<sup>1</sup> This last



*Androsace helvetica*

TAXONOMIC COLLECTIONS		
Acer	Crassulaceae	Pinaceae
Agave	Cupressaceae	Quercus
Aloe	Euphorbia	Rhipsalis
Araceae	Ferns and Lycophytes	Rhododendron
Areaceae	Galanthus	Rosa
Artemisia	Gesneriaceae	Rutaceae
Begonia	Iridaceae	Salix
Betula	Orchidaceae	Saxifraga
Bromeliaceae	Paeonia	
Cactaceae	Pelargonium	
GEOGRAPHIC COLLECTIONS		
Flora of the Alps	Flora of Madagascar	Flora of Switzerland
Flora of Corsica		
ECOLOGICAL COLLECTIONS		
La Linnaea alpine garden	Rock garden plants	Tufa wall
THEMATIC COLLECTIONS		
Carnivorous plants	Heritage fruits	Threatened plants of Switzerland
Ethnobotanical garden	Scents and touch garden	

List of the 40 living collections of the Geneva Botanic Garden, classified according to categories proposed by BGCI (Gratzfeld, 2016).

information has been provided only for collections with a clearly defined number of taxa (family, genus, or geographical flora).

### Evaluation criteria and methodology

According to Peter Wyse Jackson (1999), “a botanic garden is an institution holding documented collections of living plants for the purposes of scientific research, conservation, display and education”. Based on this definition and similar work carried out in other botanic institutions, four evaluation criteria were defined to characterise the collections: heritage, biodiversity conservation, significance for scientific research, and education. The overall cost to maintain a collection was considered in the analysis as an additional criterion, based on an annual estimate of working hours (excluding the cost of specific inputs or infrastructures such as greenhouse heating).

Each of the 40 collections were assessed by the gardener in charge of the collection and a specific scientific advisor. The aim of this approach is to connect gardeners, who contribute their practical expertise, with botanists, who provide their scientific knowledge. Each collection was discussed and evaluated using the five criteria, under the supervision of the head gardener and the living collection curator to ensure a fair and objective process. This analysis was conducted as an open discussion, leading to a jointly agreed-upon rating for each criterion. Based on the descriptive profile of the collection and the insights provided during the discussion, each criterion was then rated on a scale from 1 to 5 (1 representing low significance or cost and 5 representing high significance or cost). To facilitate visualisation and comparison while maintaining an overall perspective, the results are presented in the form of a pentagonal diagram.

<sup>1</sup> According to worldfloraonline.org

EVOLUTION OF THE GENERAL COLLECTION	2017	2023	2017>2023
Number of cultivated specimens	13,654	18,040	+32%
Number of taxa (species, sub-species, and varieties)	8,336	10,486	+26%
Number of genera	2,012	2,459	+18%
Number of families	250	272	+9%
Number of cultivars	850	1,213	+43%

Evolution of the entire living collection of the Geneva Botanic Garden between 2017 and 2023.

## Results

The strength of this analysis lies in comparing data trends between the original assessment (Freyre & Nusbaumer, 2018) and the present one (Freyre & Nusbaumer, 2024). The overall 26% increase in the number of taxa across our living collections compared to 2017 is thus remarkable.

All collections were classified into three categories based on the evaluation results. The nine priority collections are those for which the Geneva Botanic Garden has a significant responsibility, both nationally and internationally. These collections must not only be maintained but their quality and value for the future must also be enhanced. The 20 major collections will be preserved to a high standard of quality but will not necessarily be expanded. The 11 secondary collections will be maintained as they are, without prospects for further development, except in the case of extraordinary opportunities.

*“Our collections are classified into three categories: priority, major, and secondary. We have 9 priority collections, 20 important collections, and 11 secondary collections.”*

The comparison of data between these two assessments (2017–2023) allows us to observe how collections have evolved over time revealing remarkable and sometimes surprising elements, such as the significant decrease or increase in the number of taxa in certain collections. The strong dynamism (e.g., *Orchidaceae*, *Rutaceae*, *Araceae*) is often linked to the arrival of new collection managers or scientific advisors, stimulating plant and knowledge exchanges.



PRIORITY COLLECTIONS	≥ 15	2017 > 2023
Flora of the Alps	20	+2
Rock garden plants	20	+2
Arecaceae	18	+1
Flora of Corsica	18	-
Flora of Switzerland	17	+1
Gesneriaceae	17	-1
La Linnaea alpine garden	16	+1
Threatened plants of Switzerland	16	-1
Ethnobotanical garden	15	-1
MAJOR COLLECTIONS	≥ 9	2017 > 2023
Orchidaceae	13	+3
Paeonia	13	+1
Heritage fruits	13	+1
Tufa wall	12	-
Rhododendron	12	+2
Quercus	12	+1
Bromeliaceae	11	+1
Cactaceae	11	-
Pinaceae	11	+1
Rosa	11	-
Rutaceae	11	+3
Saxifraga	11	-1
Araceae	10	+2
Cupressaceae	10	+1
Euphorbia	10	-
Ferns and Lycophytes	10	+1
Iridaceae	10	-
Rhipsalis	10	-
Flora of Madagascar	9	n.a.
Galanthus	9	-
SECONDARY COLLECTIONS	< 9	2017 > 2023
Acer	8	-
Agave	8	+1
Aloe	8	n.a.
Artemisia	8	-
Crassulaceae	8	+1
Scent and touch garden	8	-1
Carnivorous plants	8	+1
Salix	8	n.a.
Begonia	7	+1
Betula	6	-1
Pelargonium	6	+2

Classification of the living collections of the Geneva Botanic Garden into Priority (score >15), Major (score >9) and Secondary (score <9) collections, based on the sum of the values from the evaluation criteria for each collection (according to the 2023 evaluation), with the evolution of the values compared to 2017.



## Conclusion

The evaluation of our collections has enabled us to categorise our collections by levels of importance, to track their evolution over time, and to set priorities for their future development. Beyond these essential indicators, this evaluation highlights the importance of collaboration between our gardeners and our scientists. Their connection is therefore essential for enhancing our botanic heritage.

*“Priority collections are almost always those for which a scientist maintains strong connections with the gardeners. This connection is therefore essential in enhancing our botanical heritage.”*

The evaluation of our living collections has highlighted both our strengths and weaknesses as a botanic garden. The collections have been clearly identified, with updated or completed development objectives for each of them. This evaluation has once again emphasised the fundamental link between Garden and Science, fostering closer collaboration between researchers and gardeners in the field. It has also allowed us to assess the results achieved, identify potential gaps, and define the improvements needed for the collection teams and their scientific advisors.

*“The priorities for the living collection of the Geneva Botanic Garden for the next ten years include continuing our strong*

*involvement in the conservation of threatened species, adapting our collections to climate change, and strengthening the connections between our living collections and our scientific research.”*

The challenges ahead for the living collections are numerous:

- Strengthen the conservation of threatened species. Continue to be involved in the conservation, propagation, and reintroduction of rare taxa in nature when environmental conditions are favourable.
- Encourage the development of living collections, particularly those for which we have significant responsibility and expertise. At the same time, acknowledge that some collections may lose value, leading to a decrease in the time and resources allocated to their care.
- Further stimulate scientific research linked to living collections, involving institutional researchers and/or external partners. Strengthen the development of collections through field missions and research programmes, both locally and internationally.
- Continue to prioritise the acquisition of wild-origin taxa (with harvest data) over those from other botanic gardens or unknown sources.

- Adapt the development of collections in response to current and future climate change.
- Align the development of our living collections with the Complementary Actions of the Global Strategy for Plant Conservation (2020-2030).

The evaluation of our living collections is scheduled to be revisited in ten years to verify if the objectives set have been met and to make decisions about the future evolution of each collection. We need to continuously challenge ourselves and constantly question the relevance of our work.

## References

- Freyre, N. & Nusbaumer, L. (2024). Living Collections Management Policy 2024-2034. Série documentaire des Conservatoire et Jardin botaniques de Genève n°51.
- Freyre, N. & Nusbaumer, L. (2018). Management Policy for the Living Collections. Série documentaire des Conservatoire et Jardin botaniques de Genève n°45.
- Global Strategy for Plant Conservation (2024). Global Strategy for Plant Conservation 2020-2030, Convention on Biological Diversity COP16, Cali, Colombia – 1 November 2024 (Decision 16/20).
- Gratzfeld, J. (ed.) (2016). From Idea to Realisation – BGCI’s Manual on Planning, Developing and Managing Botanic Gardens. 239 pp. Botanic Gardens Conservation International, Richmond, United Kingdom.
- Wyse Jackson, P. S. (1999). Experimentation on a large scale – an analysis of the holdings and Resources of Botanic Gardens. Botanic Gardens Conservation News 3 (3), 27-32.

**N. Freyre,**  
[nicolas.freyre@geneve.ch](mailto:nicolas.freyre@geneve.ch)  
 Geneva Botanic Garden,  
 Switzerland

**L. Nusbaumer and  
 N. Schoenenberger**  
 Geneva Botanic Garden,  
 Switzerland

# THE ANDAMAN PLANT BIOREPOSITORY STRENGTHENS LIVING COLLECTIONS AND DATA SHARING

*Camellia kissi* flowering twig (Sali Palode).

The Andaman Islands support a unique and highly threatened flora, yet access to well-documented plant material for research and conservation has been limited. This article describes the Andaman Plant Biorepository at the Jawaharlal Nehru Tropical Botanic Garden and Research Institute (JNTBGRI), India established under the Global Genome Initiative for Gardens. The initiative builds on existing living collections and associated field collections, using structured documentation and data management to curate herbarium vouchers and genomic tissue samples. By linking living collections with data workflows, the project demonstrates how botanic gardens can evaluate conservation outcomes and strengthen research and collaboration for island plant diversity.

## Living collections as the foundation for plant conservation

Island ecosystems are globally recognised for their high endemism and vulnerability (Kier et al., 2009). The Andaman Islands, part of the Indo-Burma biodiversity hotspot, support a unique flora shaped by long geographic isolation. Many species occur in small populations and are increasingly

threatened by habitat loss, infrastructure development and climate change. Floristically, the Andaman flora shows strong affinities with the Malaysian and Southeast Asia region, reflecting historical biogeographic connections and emphasising its global conservation significance beyond national boundaries. This makes the strategic conservation of Andaman plant diversity an urgent priority.



Anurag Dhyani collecting samples from *Cycas circinalis* (Suresh S.).

Botanic gardens play a crucial role in this context through their living collections (Havens et al., 2006). They provide a foundation for research, conservation planning and education. However, the conservation value of living collections depends on how well they are documented, evaluated and linked to broader conservation frameworks. The Andaman Plant Biorepository initiative was conceived to build on existing living and field collections, ensuring that plant material from this fragile region is systematically documented and available for long-term conservation and research.

## Project rationale and strategic focus

The Andaman Plant Biorepository was established at JNTBGRI, through a project supported by the Global Genome Initiative for Gardens (GGI-Gardens). Rather than creating new displays or conservation plantings, the project focused on curating samples derived from living collections and field established plants, supported by documentation practices.

Target taxa were identified using the [GGI Gap Analysis Tool](#), with the aim of addressing taxonomic gaps in existing conservation collections and global biorepositories. Priority was given to threatened, endemic, and under-represented taxa from Andaman Islands. The original project design targeted 41 species from 40 genera belonging to 27 families.

## Composition of the collections

During the project period (April 2024 to July 2025), samples were successfully curated from 45 plant species representing 44 genera and 33 families, exceeding the original targets. The taxonomic composition reflects the ecological diversity of Andaman forests and includes:

- Trees (24 species), forming the largest component of the collection and representing key canopy and sub-canopy taxa
- Shrubs (11 species), many restricted to evergreen forest habitats
- Herbs (10 species), including gingers and other ecologically important taxa

The collections include some species assessed under IUCN Red List threatened categories (Critically Endangered - *Cycas zeylanica*,

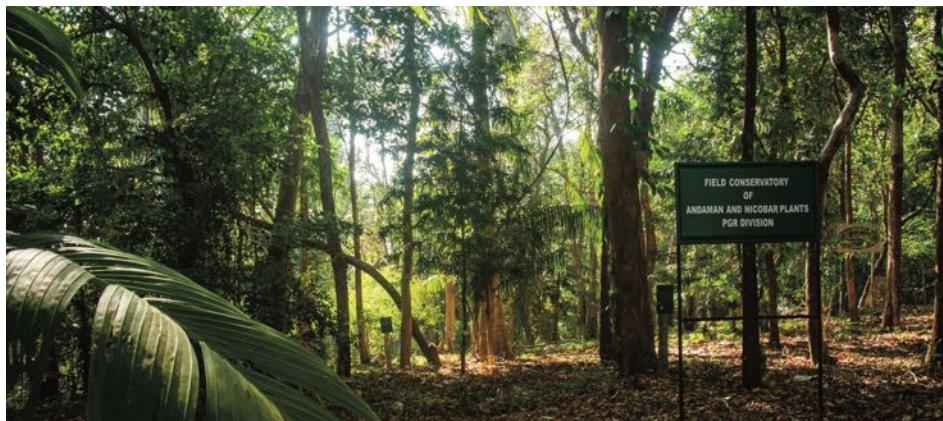

Andaman conservatory, JNTBGRI, INDIA (Sali Palode).

Endangered - *Bentinckia nicobarica*), as well as eight species endemic to the Andaman Islands (Dhyani et al., 2025). More than half of the genera curated through the project represent new additions to global genomic conservation networks.

## From living plants to documented collections

A key principle of the project was that living plants form the starting point of conservation documentation. Most target taxa were already represented in JNTBGRI's living collections or were established through field-based collections linked to the garden's research programmes. These living plants provided verified material for both voucher preparation and tissue sampling. For each species, herbarium voucher specimens were prepared and deposited at the JNTBGRI herbarium (TBGT), ensuring taxonomic verification and long-term reference.

## Biorepository samples and data management

Young leaf tissue samples were collected from documented living plants, dried using silica gel, and stored at  $-80^{\circ}\text{C}$  in secure freezers with backup power systems (Funk et al., 2017). For each species, three tissue samples were prepared to ensure long-term preservation and research utility. These samples form the core of the Andaman Plant Biorepository.

Equally important was the data associated with each sample. Accession records link living plants, voucher specimens, and tissue samples through unique identifier data. This integrated documentation allows researchers to trace each sample back to its living source, collection location, and taxonomic identity. By maintaining high data standards, the project

ensured that biorepository samples remain scientifically valuable and accessible.

## Using collection data to evaluate success

Collection data played a central role in evaluating project outcomes. Rather than measuring success solely by the number of samples collected, the project assessed achievements against conservation relevance, taxonomic breadth, and representation of priority taxa.

Data showed that the project exceeded its original species and family targets, increased representation of threatened Andaman taxa, and filled important taxonomic gaps. These metrics provided a transparent basis for reporting to funders, planning future collections, and demonstrating the conservation value of living collections and associated samples.



*Podocarpus neriifolius* (Sali Palode).

## Reflections, challenges, and future directions

Working with island floras presents challenges, including logistical constraints, limited access to flowering material, and the need for sustained data management. Following the 2004 Indian Ocean tsunami, several highly restricted plant species declined sharply or disappeared from parts of the Andaman Islands, underscoring the fragility of island ecosystems. Notably, some of these taxa survived only in *ex situ* collections, including living collections maintained at JNTBGRI, highlighting the critical insurance value of well-curated living collections. This project further demonstrated the importance of close integration between field-work, living collections, and documentation.

The Andaman Plant Biorepository illustrate how living collections, when supported by structured data and sample curation, can underpin long-term conservation and research efforts. Future work will focus on expanding taxonomic coverage, replacing sterile vouchers with fertile material, and strengthening links between living collections, restoration initiatives, and global conservation networks.

## Acknowledgement

This work is based on research published in *Plant Diversity* (Dhyani et al., 2025) and supported by the Global Genome Initiative for Gardens (GGI-Gardens), United States Botanic Garden and Botanic Gardens Conservation International, United Kingdom



Sample collection Abdul Jabbar and Asok Kumar (Sali Palode).



*Parishia insignis* infructescence (Sali Palode).

(Grant No. GGI/2024/1). First author thanks Morgan Gostel and Raakel Toppila (GGI-Gardens) for their support and guidance.

## References

- Havens, K., Vitt, P., Maunder, M., Guerrant, E.O., Dixon and K. (2006). *Ex situ* plant conservation and beyond. *BioScience*, 56(6), pp. 525–531.
- Kier, G., et al. (2009). A global assessment of endemism and species richness across island and mainland regions. *Proceedings of the National Academy of Sciences (PNAS)*, 106(23), 9322–9327.
- Dhyani, A., Sabu, K.K., Geethakumary, M.P., Jabbar, M.A., Suresh, S. and Gostel, M.R. (2025). Safeguarding Andaman flora: new plant biorepository strengthens global genome conservation. *Plant Diversity*. 47(6), 995–997.
- Funk, V., Gostel, M., Devine, A., Kelloff, C., Wurdack, K., Tuccinardi, C., Radosavljevic, A., Peters, M. and Coddington, J. (2017). Guidelines for collecting vouchers and tissues intended for genomic work (Smithsonian Institution): Botany Best Practices. *Biodiversity Data Journal*. 5: e11625. <https://doi.org/10.3897/BDJ.5.e11625>

**Anurag Dhyani**  
Jawaharlal Nehru Tropical Botanic Garden and Research Institute, Thiruvananthapuram, Kerala, India. Global Genome Initiative for Gardens (GGI-Gardens), Smithsonian Institution, Washington, DC, USA. Global Tree Specialist Group (GTSG), Species Survival Commission (SSC), IUCN, Gland, Switzerland  
Email: [anuragdhyani@gmail.com](mailto:anuragdhyani@gmail.com)

**K.K. Sabu, M.P. Geethakumary, M.A. Jabbar, S. Suresh**  
Jawaharlal Nehru Tropical Botanic Garden and Research Institute, Thiruvananthapuram, Kerala, India



*Etlingera fenzlii* habit (Sali Palode).



Xiamen Botanical Garden has carried out phenological monitoring of *Magnolia zenii* by SGPIMS.

## THE LIVING PLANT INFORMATION SYSTEM POWERS COMPREHENSIVE CONSERVATION ACTIONS FOR *MAGNOLIA ZENII*

*Magnolia zenii* is a critically endangered tree species endemic to China and is also under second-class national protection. At present, only one population of 145 mature individuals has been found. In recent years, by making full use of our self-developed plant-phenology recording system, we have carried out long-term in situ growth monitoring and ex situ cultivation-adaptation tracking. Real-time data from the backend database reveals the status of both wild plants and ex situ individuals, allowing us to schedule and fine-tune maintenance measures promptly. Through the establishment of an ex situ conservation data network that covers ten botanic gardens, schools affiliated with the Shanghai Endangered Plant Conservation Alliance, and demonstration green parks, comprehensive conservation of *M. zenii* and public awareness have advanced significantly.

With the gradual construction of China's National Botanical Garden Network and the escalating demand for biodiversity conservation, botanic gardens—whose core missions are the *ex situ* conservation of living plants and the safeguarding of plant germplasm—urgently need a modern, shared information platform for living-plant management. Shanghai Botanical Garden (SHBG), poised to join the national network, operates under five mandates—*ex situ* conservation, scientific research, horticultural display, science education, and resource utilisation—that mirror the responsibilities of any national-level garden worldwide. Globally, botanic gardens have evolved into data-rich institutions that archive, study and interpret living plant collections, but they now face unprecedented challenges—and opportunities—brought by the digital age. Broad application of information technologies promises to raise management efficiency, accelerate research, enhance visitor experience, and foster international collaboration for plant diversity conservation.

Living-plant management and information technology are inseparable. Yet gardens founded decades—or centuries—ago often used disparate, analogue recording methods, resulting in data gaps and lost continuity of information. Evaluations of *ex situ* collections have therefore lacked system-wide rigour, while data storage, updating and sharing have lagged, constraining conservation science and weakening the emerging national *ex situ* system. These shortcomings also reduce the contribution of botanical introductions to economic development and to the upgrading of bio-industries.

Drawing on international best practice and its own long history, SHBG designed the Shanghai Botanical Garden Plant Information



Field phenological records and micro-meteorological station data for *Magnolia zenii* of SGPIMS.



Training students from Shanghai High School to conduct phenological monitoring of *Magnolia zenii*.

Management System (SGPIMS). The platform contains five thematic databases and eight operational sub-systems that integrate field collection, introduction and conservation, specialised garden construction, plant maintenance, scientific research, nursery management and demonstration sites into one digital workflow.

We use SHBG's flagship species, the critically endangered and nationally protected *Magnolia zenii*, to demonstrate the power of SGPIMS. Only 145 mature trees persist in the wild; our system now tracks every individual and every subsequent conservation step.

### Full-process, closed-loop traceability

- *In situ* module: demographic and habitat monitoring, community-plot updates, camera-trap records of seed predation.
- *Ex situ* module: links introduction, accessioning, mapping, phenological observation and maintenance into a single, searchable chain.

### Inter-institutional data sharing

Early in 2025 SHBG distributed about 200 nursery-raised *M. zenii* plants to nine botanic gardens spanning China's major climate zones—from Beijing in the north to Xishuangbanna in the south—creating a distributed common-garden experiment. Participants upload phenological and growth data to SGPIMS in real time.

Within Shanghai, 36 young trees have been planted at five urban demonstration sites; 1,000+ phenology records have already

been logged. Additionally, 70 trees were installed in 14 primary and secondary schools in Xuhui District. Students monitor budburst, flowering and leaf fall through the system's citizen-science portal, integrating hands-on conservation into their curriculum. Interactive courses, social-media posts and on-site interpretation have turned *M. zenii* into a local "celebrity species", greatly amplifying public awareness and overall conservation impact.

By generating large, long-term and standardised datasets, SGPIMS supplies researchers, educators and conservation practitioners with the evidence needed to refine propagation protocols, select optimal reintroduction sites and measure conservation success. In the digital era, data have become a "second forest"; SHBG's experience shows that when every plant is a data point, even the rarest species can escape the extinction vortex. We have transformed our *in situ* conservation and botanic garden *ex situ* work into a documentary that is screened in diverse venues, and we run both online and offline training sessions—including on-site phenology workshops—to sharpen the conservation skills of reserve staff and students.

**Wei Yukun, Gu Junzhe, Chu Xiuli, Qian Shukuan, Luo Juan, Yan Wei, Shanghai Botanical Garden, Shanghai China**

**Wen Xiangying South China National Botanical Garden, Guangzhou, China. Botanic Gardens Conservation International China Office, Guangzhou, China.**



## ADAPTING A LIVING COLLECTIONS MANAGEMENT SYSTEM FOR GLOBAL *EX SITU* CONSERVATION

Collecting epiphytic orchids: Jean Yves Serein, climbing a 50-meter tree in Gabon (Tariq Stévert).

The Missouri Botanical Garden is extending its Living Collections Management System (LCMS) to support ex situ conservation work in their Africa and Madagascar programs. Originally developed to support the tracking of living collections at their St. Louis properties, LCMS is now being adapted to manage field genebanks, orchid shadehouses, and restoration projects across multiple countries. Effective data management, including monitoring, labeling, and tracking plants over time, is essential for living collections to deliver conservation value, regardless of location. Accessible, user-friendly systems enable geographically dispersed teams to maintain rigorous documentation standards that underpin plant conservation work.



Orchid montage showing different ways to grow living orchid specimens in the tropics (Vincent Droissart).

The Missouri Botanical Garden (MBG) was founded in 1859 with a mission to discover and share knowledge about plants and their environment in order to preserve and enrich life. The living collections are at the very heart of our mission and comprise over 17,000 documented taxa across four properties in the Greater St. Louis Area. These collections include both ornamental and horticultural varieties that connect visitors with plants and landscapes from around the world and include a growing number of rare and at-risk species. They serve as the foundation for meeting key horticultural, educational, research, and conservation objectives in support of the mission.

Effective data management of living collections, including monitoring, labeling, and tracking plants over time, are core criteria for a botanic garden and form the basis for conservation value, scientific credibility, and responsible plant exchange (BGCI). MBG was an early adopter of collections management technology

beginning in the 1980s. After decades of iterative development across multiple, disconnected databases, MBG received funding from the Institute of Museum and Library Services (IMLS) in 2012 and began the development of a unified platform: the Living Collections Management System (LCMS).

Developed in-house by MBG's Biodiversity Informatics team, LCMS evolved over the past 14 years through sustained internal and external investments. The system supports comprehensive tracking of living plant material, from collection in the wild, through propagation, cultivation, inventory, and long-term management. As a web-based platform, LCMS has improved data quality and accessibility for staff, increased the long-term value of the living collection, and enhanced the public's understanding of MBG's living collections and conservation work. To date, the primary users of LCMS have been horticulturists, propagators, horticulture managers, and plant records staff engaged in the curatorial process.

As the role of ex situ conservation continues to expand across botanic gardens worldwide, so too has the scope of what constitutes a "living collection." **Field genebanks, seed amplification projects, restoration plots, and conservation nurseries now play critical roles in safeguarding plant diversity.** As MBG's global conservation programmes have grown, particularly in regions such as Africa and Madagascar, there has been a corresponding need to extend LCMS beyond the traditional botanic garden setting.

MBG's Madagascar Research and Conservation Program, built over three decades, now has several in-country offices and 50 full-time staff members. For much of its history, the programme has focused on taxonomic research, botanical exploration, and in-country capacity building, with special emphasis on training and disseminating botanical information. MBG staff and associates have completed hundreds of scientific studies, implemented a highly productive field inventory programme, and shared botanical knowledge through a freely available electronic catalogue of the Madagascan flora. More recently, MBG has become a leader in community-based conservation, with 11 sites across the country, as well as a major player in restoration, planting approximately 500,000 trees each year.



Field gene bank in Kinguélé, Gabon (Nicolas Texier).

In 1970, MBG was recognised as the North American center for the study of African botany, in response to a call from international botanists to complement European and African efforts. In collaboration with local botanists and in-country institutions, MBG's work has focused on biodiversity-rich regions, especially Central Africa (primarily Gabon, but also Cameroon, Equatorial Guinea, São Tomé & Príncipe), East Africa (Tanzania, Kenya, and Uganda), and South Africa, with additional involvement in 22 other countries.



Growing orchids in Gabon (Tariq Stévant).

In Africa, 70% of the epiphytic flora are orchids (Stévant, 2003; Droissart, 2009). Our experience has shown that nearly 90% of epiphytic orchids encountered in the field are sterile at the time of collection and therefore nearly impossible to identify. To overcome this challenge and obtain fertile, identifiable material, a shadehouse cultivation system was first developed in Africa in 1997.

With support from the U.S. National Science Foundation in 2006, MBG's shadehouse network expanded across continental Africa and Madagascar in collaboration with African and international partners. This approach fostered efficient and cost-effective sampling procedures for epiphytes, yielding high quality liquid-preserved specimens, photos, and more recently, leaf tissue for phylogenetic analyses, as well as root tissue for cytological analyses and the study of mycorrhizae.

For fertile plants collected in the field, an herbarium specimen is prepared on-site, accompanied by photographs and silica-gel samples, and the living plant is then brought to the shadehouse for cultivation. Sterile plants collected in the field are placed directly in cultivation and monitored by a local botanist until flowering, at which time a full set of herbarium specimens is prepared. Detailed collection data, such as geographic coordinates, habitat, ecology, altitude, phenology, and other relevant information are recorded for each specimen and entered into a Microsoft Access database. All cultivated plants are tagged to maintain a clear association with their collection data.

**Field genebanks and orchid shadehouses are living collections that present unique management challenges requiring purpose-built data tracking solutions.** Living plants require a database solution that can record repeated observations, manage sexual and asexual propagation events from accessioned plants, maintain relationships between individuals derived from the same maternal plant, and link to associated herbarium vouchers, maps, images, and documents. While Microsoft Access initially provided adequate data management for living collections in Africa's field genebanks and orchid shadehouses, the system has become increasingly outdated. Poor access speeds and the inability to support simultaneous users have created bottlenecks in collections care and management and has become a barrier to progress.

The need to improve tracking of living plant collections data in MBG's ex situ programmes in Africa and Madagascar has been recognised for nearly a decade. In 2017, divisional leaders proposed extending LCMS to support field genebanks in Madagascar, starting with Parc Ivoloïna. Because LCMS was originally developed in collaboration with Desert Botanical Garden (United States), the only other institution using the platform, the system already supported multiple datasets. Adding Madagascar required developers to create a new dataset with both shared support tables (such as family, habit, and provenance) and dataset-specific tables (such as taxon, accession, areas, and beds). LCMS also incorporates spatial data through custom

basemaps developed in Esri's ArcGIS that sync with defined properties, areas, and beds.

Despite this successful initial implementation, the Madagascar dataset remained underutilised for several years due to competing institutional priorities and limited staffing. During this period, the Africa and Madagascar team continued their conservation work, maintaining detailed living collections data for field genebanks throughout Madagascar and for orchids cultivated in shadehouses across multiple countries. **The orchid collections served dual purposes as both reference specimens for taxonomic work and as part of propagation trials and, in some cases, reintroduction efforts.**

In 2025, staff from the Africa and Madagascar Department approached Rebecca Sucher (Director, Living Collections and Conservation Horticulture) at MBG to support an expansion of their efforts to propagate and systematically track living plants. Initial discussions to assess current activities and future needs revealed that substantial efforts were already underway to manage living collections across multiple countries.



Orchid shade house in Guinée (Ehoarn Bidault) and Orchid label (Tariq Stévant).



# LIVING COLLECTIONS, DATA AND BOTANIC GARDENS' NETWORKS: STRENGTHENING CONSERVATION HORTICULTURE THROUGH TRAINING



Verband Botanischer Gärten Gardener in Botanical Species Conservation 2025-2026.

## Introduction

**B**otanic gardens are custodians of plant diversity, yet the true value of living collections lies not simply in what is grown, but in how those collections are managed, documented and used to deliver measurable conservation outcomes. As the role of botanic gardens as conservation actors increases, the professional capacity behind living collections has become as important as the collections themselves.

At the centre of this challenge sits conservation horticulture: the application of horticultural skills, scientific understanding and documentation to ensure plants in cultivation actively support species conservation, restoration and recovery.

Achieving and sustaining these standards rarely happens at the level of individual gardens alone, and regional and national botanic gardens' networks play a decisive role in translating conservation horticulture standards into practice, building horticultural capacity and standardising processes and data management. This article explores the importance of such networks in

delivering conservation horticulture training, the central role of living collections data, and how network-based programmes in Germany and the Caribbean and Central America region demonstrate effective, scalable approaches in building professional capacity in the sector. It also brings this capacity building within the context of the BGCI Accreditation Scheme, which provides an internationally recognised framework that articulates these expectations, setting standards for governance, collections policy, documentation and conservation practice.

## Why regional and national networks matter for training?

While individual gardens may develop internal training initiatives, regional and national networks serve as platforms to facilitate knowledge exchange and provide the scale, continuity and diversity of expertise required to deliver conservation horticulture training effectively. Their importance can be summarised across four key areas:

1. Translating global standards into local practice: Networks act as intermediaries between international frameworks, such as BGCI Accreditation, and local realities. They help interpret global criteria in ways that reflect regional floras, legal frameworks, and institutional capacities, making training both relevant and achievable.
2. Sharing specialist expertise: Advanced conservation horticulture skills — seed banking, ex situ management, genetic considerations, restoration— are often concentrated in a small number of institutions. Networks enable these centres of expertise to support others, maximising the impact of limited specialist capacity.
3. Building professional communities: Training delivered through networks fosters peer learning and long-term professional relationships. These communities of practice are critical for sustaining standards, troubleshooting challenges and embedding conservation thinking into routine horticultural work.



The seven theory modules cover: legal frameworks for species conservation; seed banking, conservation collections and reintroduction; seed biology and germination ecology; pollination biology and prevention of hybridisation; cultivation factors for reintroduction projects; plant systematics and taxonomic competence; and communication and rhetoric for horticulturists. A core emphasis lies in documentation standards, traceability of provenance, genetic considerations, and the avoidance of maladaptation to garden conditions—competencies typically absent from standard horticultural training.

4. Strengthening evidence and accountability: Networks facilitate standardised approaches to documentation and data management, improving comparability across institutions. This strengthens both individual institutions and collective reporting on conservation impact at regional or national levels.

### Living collection data: the backbone of conservation horticulture

High-quality data underpins every aspect of conservation-focused living collections. Within conservation horticulture training programmes, particular emphasis is placed on ensuring staff understand not only how to record data, but why it matters. These include data and processes for taxonomic verification, recording of provenance, maintaining genetic diversity in *ex situ* collections, recording horticultural history such as propagation methods used, losses and movement of material within the collection and continuous monitoring and evaluation.

When this data is collected consistently and reviewed regularly, living collections become dynamic conservation tools. They enable strategic collection planning, gap analysis and informed decision-making, directly supporting BGCI Accreditation criteria. Network-based training is particularly effective in embedding these practices, as it

promotes shared standards and collective learning rather than isolated compliance.

### Case Study 1: A National Approach in Germany

Germany provides a strong example of how coordinated national action can strengthen professional capacity in conservation horticulture. In response to accelerating plant species decline—currently affecting around one third of Germany's flora and a clear skills gap in traditional horticultural training—the Association of Botanical Gardens (Verband Botanischer Gärten, VBG), in cooperation with the Wildpflanzenschutz Deutschland (WIPs-De) initiative and academic partners, and using the experience gained from the WIPs-De network (Wild Plant Conservation Germany), established the advanced training programme “Gärtnerin/Gärtner im Botanischen Artenschutz” (Conservation Techniques Course).

The course is explicitly designed to address the shortage of qualified conservation practitioners in botanical gardens. Its target group is horticultural staff below team leader level—those directly responsible for hands-on conservation work in living collections, seed banks, and reintroduction projects. By focusing on operational staff, the programme strengthens implementation capacity where it is most critical.

### High-quality data underpins every aspect of conservation-focused living collections.

The modular course comprises 150 hours in total. It combines seven two-day theoretical modules with a 40-hour professional placement (Hospitation) at an institution conducting *in situ* conservation activities and concludes with a 2,500-word thesis and oral presentation. The curriculum integrates both *ex situ* and *in situ* conservation approaches, reflecting current best practice in integrated species recovery strategies.

By linking horticultural techniques directly to conservation data requirements, the programme reinforces professional standards in collection management and species recovery. Delivered across multiple botanical gardens, it fosters a shared professional language, harmonised methodologies, and a national peer network. The course therefore represents both a strategic response to workforce shortages and a scalable model for coordinated, practice-oriented conservation training at national level.

### Living collections within the BGCI Accreditation framework

The [BGCI Accreditation Scheme](#) positions living collections as strategic assets rather than static displays. Accreditation assessment focuses on how collections are planned, justified, documented and reviewed in relation to institutional mission and conservation priorities. Key expectations include:

- A clearly articulated collections policy linked to conservation, research, visitor engagement and education goals.
- Evidence of conservation, research and engagement activities, such as activities centred around threatened species, endemic or native taxa held in the collections.
- Consideration of genetic diversity and provenance, particularly for wild-origin material, which are particularly important for those gardens aiming for Conservation Practitioner and Advance Conservation Practitioner Accreditations.
- Robust documentation systems that support monitoring, review and reporting, rooted in the definition of a botanic garden which is centred in ‘documented living collections’.

These requirements highlight a crucial point: accreditation is not achieved solely through policies or databases, but through staff competence. Gardeners, horticulturists and collections managers must understand how their daily practices — propagation, cultivation, record-keeping and monitoring — contribute to institutional compliance and conservation impact. Accreditation therefore becomes a powerful driver for structured, targeted training in conservation horticulture.

## Networks as enablers of accreditation

When training is deliberately aligned with accreditation requirements, networks become strategic enablers rather than informal associations. For gardens pursuing BGCI Accreditation, participation in recognised regional or national training programmes provides:

- Evidence of staff competence and professional development.
- Demonstrable improvements in living collection documentation and management.

- Clear alignment between policy, practice and conservation outcomes.
- Peer support that sustains progress beyond individual training events.

From BGCI's perspective, such network-based approaches also strengthen the credibility and comparability of accredited gardens globally, reinforcing accreditation as a meaningful benchmark of excellence.

*Accreditation is not achieved solely through policies or databases, but through staff competence.*

## Case Study 2: The Role of the Caribbean and Central American Botanic Gardens Network



[The Caribbean and Central American Botanic Gardens \(CCABG\) Network](#) illustrates the value of regional collaboration in a context characterised by high biodiversity, limited resources and diverse

institutional capacities. In partnership with BGCI and supported by external funders, the Leon Levy Foundation, CCABG Network has implemented a multi-year programme designed specifically to support gardens working towards BGCI Accreditation.

Central to this initiative is a structured focus on collections evaluation, helping participating gardens develop or refine collections policies aligned with their missions and regional conservation priorities. Training workshops — delivered in both English and Spanish — guide participants through assessing the conservation value of their living collections, improving documentation and identifying gaps and opportunities.

A defining feature of the programme is its emphasis on practical application. Participants work directly with their own collection data, applying accreditation criteria to real-world scenarios rather than hypothetical examples, and adapt their collection policies and strategies accordingly. This approach demystifies accreditation, reframing it as a strategic planning tool rather than a purely administrative process.



19 gardens in the Caribbean and Central America region started in 2025 a 3 year programme. Three online sessions have already been delivered in 2025, with the first year focusing on the development of the garden's collections policy. The sessions are delivered in two languages Spanish and English, and supported through documentation and materials via [BGCI's online training platform](#) and accreditation materials.

Furthermore, a series of in person workshops have taken place for members of the CCABG Network with the aim of fostering collaboration, knowledge exchange and building capacity to strengthen plant conservation across the region. The topics for these trainings ranged from general conservation horticulture, from plant health and biosecurity in botanic gardens, to developing propagation protocols for threatened tree species. During these courses, participants commit themselves to sharing their learning experiences with colleagues at their institutions or producing a formal output such as a propagation protocol for a chosen species. In this way, knowledge is not limited to the course itself but is cascaded to others reinforcing the impact and value of the regional network.

Beyond formal workshops, CCABGN strengthens professional connections through regional meetings such as the [Botanical Bridges Congress](#), providing platforms for peer exchange and continued learning.

Collectively, these efforts demonstrate how a regional network can build capacity, standardise practice and support diverse institutions in meeting international standards—even in resource-constrained settings.

## Conclusions

Living collections are only as effective as the people and data that support them. As



Four-day workshop on 'Propagation Protocols for Threatened Trees' at the Centro Agronómico Tropical de Investigación y Enseñanza (CATIE), Costa Rica home to the Jardín Botánico Dr. Jorge León Arguedas. This workshop organised by the CCABG Network was attended by 23 participants from 11 Latin American and Caribbean countries in September 2025.

botanic gardens face increasing pressure to demonstrate conservation relevance and accountability, investment in networks and training emerges as a strategic priority.

The examples from Germany and the Caribbean and Central America show how national and regional networks can translate global frameworks into practical action,

elevate professional standards and strengthen conservation impact. By also embedding BGC Accreditation principles into training, these networks ensure that living collections are not only well maintained but purposefully managed for long-term biodiversity conservation.

In this sense, the future of living collections lies as much in collaboration and capacity building as in the plants themselves and it requires connected communities of practice, shared resources, and structured training aligned with global standards.



Participants experiment with different growing media during the 'Propagation Protocols for Threatened Trees' workshop at CATIE, Costa Rica.

**Patricia Malcolm**  
Botanic Gardens Conservation International

**Noelia Álvarez de Román**  
Botanic Gardens Conservation International

**Dr. Elke Zippel**  
Botanischer Garten Berlin

**Markus Radschelt**  
Botanische Gärten der Universität, Bonn

# THE ILLEGAL PLANT TRADE COALITION (IPTC)

IPTC unites the global botanic community, and key stakeholders ranging from the horticultural industry to interested individuals and local stakeholders to tackle the illegal plant trade. Through collaboration, resources, and behaviour-change strategies, the Coalition empowers action to protect plants, from illegal wild harvest through to smuggling and sales.

Our Coalition has innovative approaches, a toolkit, cross-sector engagement, and opportunities to strengthen global efforts against plant crime.

We are taking the conversation on illegal wildlife trade beyond fauna to include flora. <https://www.bgci.org/our-work/networks/illegal-plant-trade/>



## PLANT POACHING IS A GLOBAL ISSUE

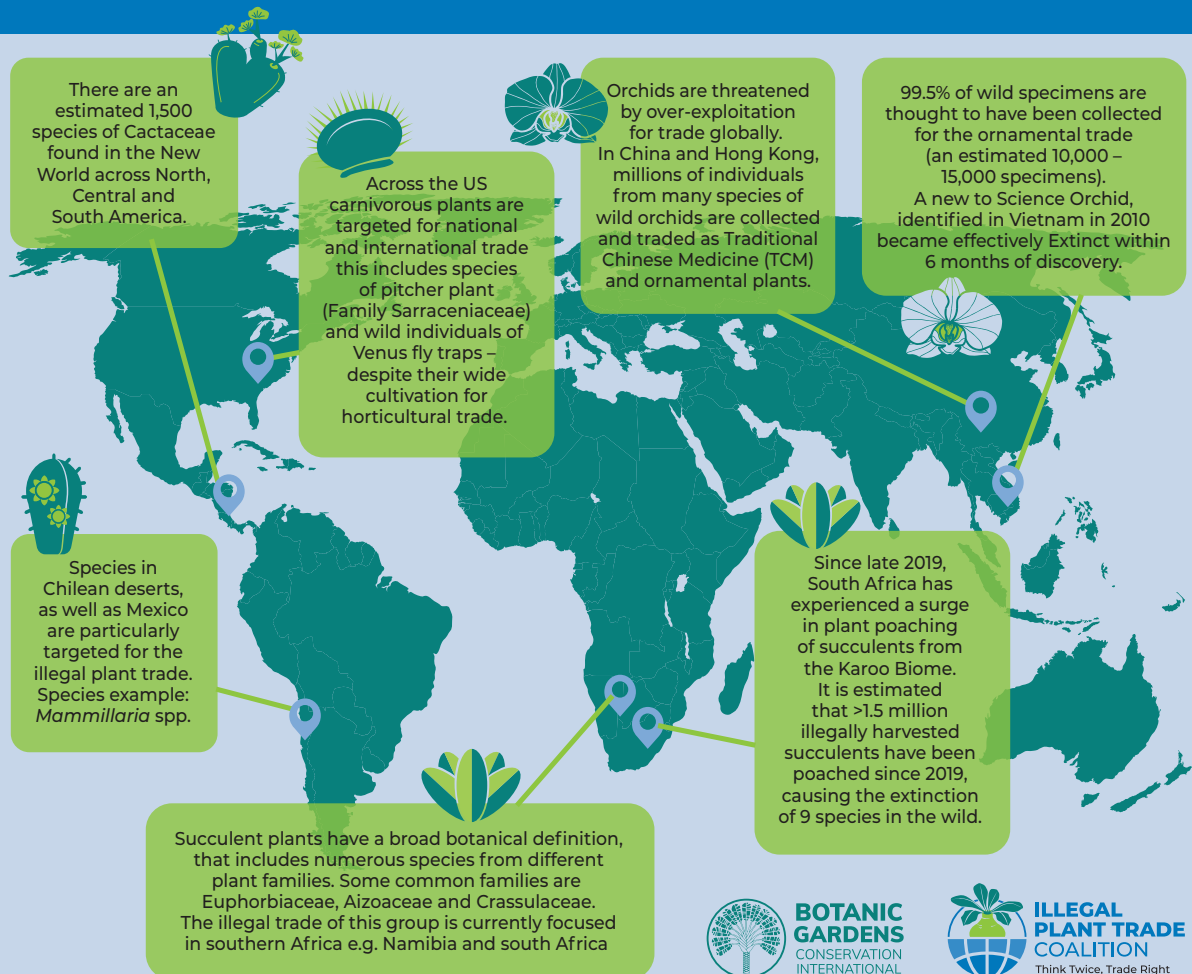

# ITS EASY TO JOIN BOTANIC GARDENS CONSERVATION INTERNATIONAL



BGCI is a non-profit membership organisation, representing plant conservation institutions worldwide. We advocate for the botanical community, promoting the role of botanic gardens in plant conservation policy, practice and education; we connect people to exchange ideas; we provide training and learning resources; and we provide funding and technical support to efforts aimed at saving plants.

Becoming a BGCI member is a great way to support the global botanical community; income from membership goes right back through to the development of publications, training materials, funding, and more.

By joining BGCI, your institution and staff will be part of the largest global network of botanic gardens and institutions in conservation, and have access to a range of dedicated services:

- Grants through the [Global Botanic Garden Fund](#)
- The [Botanic Garden Accreditation Scheme](#)
- Subsidised training courses through [BGCI's Online Training Platform](#)

- Discounted [Congress](#) attendance (BGCI Global, Education, and Horticulture Congresses)
- Ability to publish in [BGjournal](#) (conservation) and [Roots](#) (education)
- Use of the BGCI website to [promote your events, news, and job listings](#)
- Permission to use BGCI's logo and name
- A membership pack and Certificate of Membership

**BGCI member institutions** pay an annual fee in alignment with their annual budget (see the table below). If you are not an institution but are interested in joining BGCI, you can still become an individual member, this will give you access to all our training courses and discounted Congress attendance (including BGCI Global, Education, and Horticulture Congresses).

Budget Size (in USD)	Annual Fee (GBP)	Annual Fee (USD)	Annual Fee (EUR)	Category
Greater than \$2.25 million	£1,372	\$1,830	€1,640	Category B
\$1.5 to \$2.25 million	£745	\$995	€890	Category C
\$750,000 to \$1.5 million	£550	\$735	€655	Category D
\$100,000 to \$750,000	£300	\$400	€360	Category E
Less than \$100,000	£140	\$190	€170	Category F



## Annual fees for individual membership

Currency	12 Month Fee
GBP	£100
USD	\$130
EUR	€120



**BOTANIC GARDENS**  
CONSERVATION INTERNATIONAL



**BOTANIC  
GARDENS**  
CONSERVATION  
INTERNATIONAL

Descanso House, 199 Kew Road,  
Richmond, Surrey, TW9 3BW, U.K.  
Tel: +44 (0)20 8332 5953  
E-mail: info@bgci.org  
Internet: www.bgci.org  
https://twitter.com/bgci

**BGjournal** Volume 23 • Number 1 • April 2026 ISSN 1811-8712

## TURN COLLECTIONS INTO CONSERVATION IMPACT

Botanic gardens collectively hold one of the world's most important resources for plant conservation - but its true value depends on how visible and accessible it is.

We invite all gardens to contribute to and regularly update their data in GardenSearch and PlantSearch.



**BGCi  
Garden  
Search**



**BGCi  
Plant  
Search**

**EVERY  
RECORD MATTERS**  
Ensure your garden's  
data is contributing  
to global plant  
conservation

**UPDATE  
TODAY**

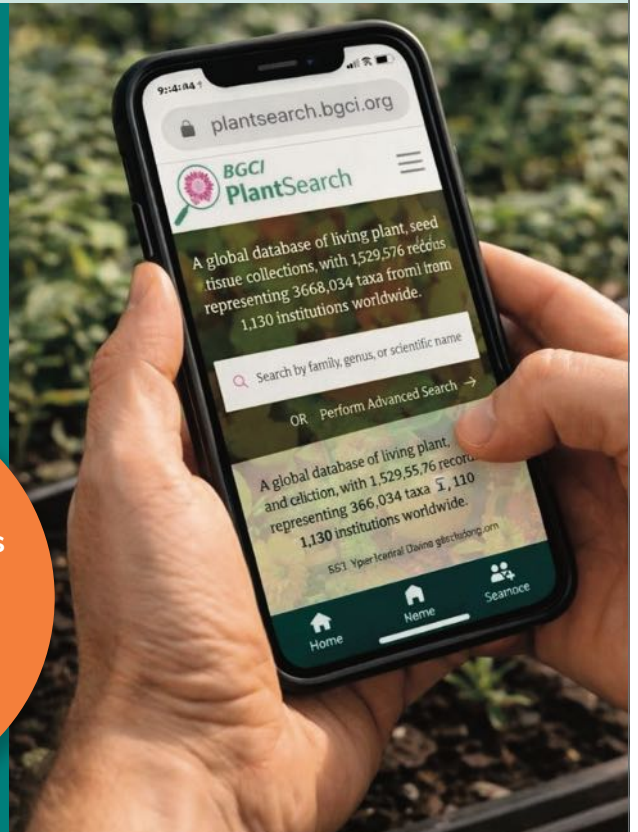

**BOTANIC GARDENS**  
CONSERVATION INTERNATIONAL

[plantsearch.bgci.org](http://plantsearch.bgci.org)

### BGjournal

The next **BGjournal** issue will be all about **metacollections** and how **botanic gardens** can contribute. Please see BGCi's new items and Cultivate newsletter for information on how to contribute.